

# AcuLink 810 Data Acquisition Server User's Manual

Copyright © 2022 V1.20

This manual may not be altered or reproduced in whole or in part by any means without the expressed written consent of Accuenergy.

The information contained in this document is believed to be accurate at the time of publication, however, Accuenergy assumes no responsibility for any errors which may appear here and reserves the right to make changes without notice. Please ask the local representative for latest product specifications before ordering.

Please read this manual carefully before installation, operation and maintenance of the AcuLink810 data acquisition server. The following symbols in this manual are used to provide warning of danger or risk during the installation and operation of the equipment.



**Electric Shock Symbol: Carries information about procedures which must be followed to reduce the risk of electric shock and danger to personal health.**



**Safety Alert Symbol: Carries information about circumstances which if not considered may result in injury or death.**

Prior to maintenance and repair, the equipment must be de-energized and grounded. All maintenance work must be performed by qualified, competent accredited professionals who have received formal training and have experience with high voltage and current devices. Accuenergy shall not be responsible or liable for any damages or injuries caused by improper meter installation and/or operation.

# Table of Contents

<b>Chapter 1: Overview</b>	<b>6</b>
<b>Chapter 2: Functional Description</b>	<b>7</b>
2.1 <b>Hardware Specifications</b>	<b>7</b>
2.2 <b>Power</b>	<b>7</b>
2.3 <b>Communication</b>	<b>7</b>
2.4 <b>Inputs</b>	<b>7</b>
2.5 <b>Environment</b>	<b>8</b>
<b>Chapter 3: Appearance and Dimensions</b>	<b>9</b>
<b>Chapter 4: Installation</b>	<b>10</b>
4.1 <b>Installation Checklist</b>	<b>10</b>
4.1.1    Optional Hardware:	10
4.1.2    LAN Information	10
4.1.3    Installation Safety Requirements and Considerations	10
4.2 <b>Powering the unit</b>	<b>11</b>
<b>Chapter 5: LED Description</b>	<b>12</b>
5.1 <b>AcuMesh LEDs</b>	<b>12</b>
5.2 <b>WiFi LEDs</b>	<b>13</b>
5.3 <b>RS485 LEDs</b>	<b>14</b>
<b>Chapter 6: Initializing the AcuLink 810</b>	<b>15</b>
6.1 <b>Accessing the AcuLink 810 Web Interface</b>	<b>15</b>
6.1.1    Method 1 - Direct Connection via Ethernet	15
6.2 <b>Dashboard</b>	<b>22</b>
6.2.1    About Page	22
<b>Chapter 7: Device Templates</b>	<b>24</b>
7.1 <b>Modbus Templates</b>	<b>24</b>
7.1.1    Import Template	25
7.1.2    New Template	26
7.1.3    Typical Energy Meter Template	30

7.1.4	Creating Template from CSV .....	32
<b>7.2</b>	<b>BACnet Template .....</b>	<b>34</b>
7.2.1	Import Template.....	35
7.2.2	Convert from EPICS File .....	36
<b>Chapter 8: System Settings .....</b>		<b>38</b>
<b>8.1</b>	<b>Network .....</b>	<b>38</b>
8.1.1	Ethernet .....	38
8.1.2	WiFi.....	39
8.1.3	HTTP Proxy.....	41
8.1.4	RSTP.....	41
8.1.5	Default Routing Interface .....	42
<b>8.2</b>	<b>Whitelist .....</b>	<b>43</b>
<b>8.3</b>	<b>Time &amp; Date .....</b>	<b>44</b>
<b>8.4</b>	<b>Remote Access.....</b>	<b>45</b>
<b>8.5</b>	<b>User Management .....</b>	<b>47</b>
8.5.1	General .....	47
8.5.2	User Configuration .....	48
8.5.3	Role Configuration.....	49
8.5.4	Password Policy.....	49
8.5.5	Password Management.....	50
<b>8.6</b>	<b>Certificate Management .....</b>	<b>50</b>
<b>8.7</b>	<b>Configuration Management.....</b>	<b>51</b>
<b>Chapter 9: Protocols .....</b>		<b>53</b>
<b>9.1</b>	<b>Modbus .....</b>	<b>53</b>
9.1.1	RS485 Devices .....	53
9.1.2	USB Devices.....	54
9.1.3	Adding Modbus RTU Device .....	54
9.1.4	TCP Devices .....	57
9.1.5	Adding Modbus TCP Device.....	57
9.1.6	Modbus Gateway Function .....	60

<b>9.2</b>	<b>AcuMesh .....</b>	<b>61</b>
9.2.1	Local Configuration .....	61
9.2.2	Scan & Remote Configuration.....	63
	Managed Nodes.....	65
	Reset Nodes .....	66
9.2.3	AcuMesh Diagnostics.....	66
9.2.4	Adding AcuMesh Device.....	67
9.2.5	Search Modbus Device.....	70
<b>9.3</b>	<b>Modbus Polling.....</b>	<b>72</b>
<b>9.4</b>	<b>BACnet.....</b>	<b>73</b>
9.4.1	BACnet MS/TP .....	73
9.4.2	Adding BACnet MS/TP device .....	76
9.4.3	BACnet IP.....	77
9.4.4	Adding BACnet IP device .....	79
9.4.5	Search BACnet Device .....	81
9.4.6	BACnet Gateway.....	82
9.4.7	BBMD .....	84
<b>9.5</b>	<b>MQTT Protocol .....</b>	<b>84</b>
9.5.1	MQTT General Settings.....	85
9.5.2	MQTT Authentication .....	86
9.5.3	MQTT Encryption.....	86
9.5.4	Last Will & Testament .....	87
9.5.5	Device Publishing.....	88
<b>9.6</b>	<b>Azure IoT .....</b>	<b>89</b>
9.6.1	Creating Azure IoT Device on Azure Portal Server.....	90
9.6.2	Create an IoT devices /IoT Edge device in the Azure portal .....	91
9.6.3	Retrieving the connection string in the Azure portal.....	93
9.6.4	Configure AcuLink 810 from Azure .....	93
<b>9.7</b>	<b>SNMP .....</b>	<b>94</b>
9.7.1	MIB File .....	95
<b>9.8</b>	<b>MBus.....</b>	<b>96</b>

9.8.1	Adding MBus Device .....	96
<b>9.9</b>	<b>Virtual Device .....</b>	<b>100</b>
9.9.1	Adding Virtual Parameter .....	101
<b>Chapter 10: Device Readings .....</b>		<b>104</b>
10.1	Parameter Definition .....	105
10.2	Writing To Modbus Device .....	107
<b>Chapter 11: Digital Inputs .....</b>		<b>110</b>
11.1	Device Alarm .....	112
11.2	Alarm Log .....	114
11.3	Email Alarm Notifications .....	115
<b>Chapter 12: Data Logging .....</b>		<b>117</b>
12.1	Data Loggers .....	117
12.1.1	Rapid Logger .....	119
12.2	Post Channels .....	120
12.2.1	HTTP Post Method .....	120
12.2.2	FTP Post Method .....	121
12.2.3	SFTP Post Method .....	123
12.3	Downloading Data .....	123
12.4	AcuCloud .....	124
<b>Chapter 13: Network Diagnostics .....</b>		<b>129</b>
<b>Chapter 14: Maintenance .....</b>		<b>134</b>
14.1	System Status .....	134
14.2	Event Log .....	135
<b>Chapter 15: Firmware Update .....</b>		<b>136</b>
15.1	Auto Firmware Update .....	136
15.2	Manual Update .....	136
15.3	Remote Update .....	139
<b>Chapter 16: Reset Button .....</b>		<b>142</b>

# Chapter 1: Overview

The AcuLink 810 is an intelligent data acquisition server and gateway that allows users to collect data from all Accuenergy meters, sensors and other third-party devices.

The AcuLink collects and logs time-stamped data from connected downstream devices (serial or Ethernet), and is able to store this data locally in non-volatile memory. When using Ethernet it is possible to push or pull data using HTTP or FTP protocols as well as pushing data to different web-based energy management systems or any front-end software platform. There is no software required for the AcuLink as all configuration is done from the gateway's web interface.



# Chapter 2: Functional Description

## 2.1 Hardware Specifications

- **Disk Capacity:** 8 GB RAM
- **Interval Recording:** 1-1440 minutes, user selectable
- **LEDs:** Power, Ethernet, WiFi, Modbus TX/RX, AcuMesh

## 2.2 Power

- **Power Supply:** 24VDC, 500mA

**NOTES:** This unit is to be sourced by a Class 2 power supply with the following output: 24VDC, 500mA min not to exceed 8A.

- **Isolation:** RJ45 Ethernet 1500Vrms  
RS485 2500Vrms  
Digital Input 5000Vrms

## 2.3 Communication

- **Protocols Supported:** Modbus RTU, Modbus TCP, BACnet MS/TP, BACnet IP, HTTP/HTTPS, FTP, NTP, SMTP, RSTP, MQTT, MBus, SNMP, SunSpec
- **LAN:** 2 x RJ45 10/100 Ethernet, full half duplex, auto polarity
- **WiFi:** 802.11 b/g/n, 2.4GHz
- **USB:** USB expansion port, USB 2.0 Host

## 2.4 Inputs

- **RS485 Port:** RS485 Modbus, supports up to 32 external devices (expandable)
- **Baud Rate:** 9600-115200 bps
- **USB Port:** Modbus via RS485-USB converter, supports up to 32 external devices

- **Baud Rate:** 9600-115200 bps

- 
- **Digital Input:** 8 pulse counters
  - **Input Voltage Range:** 8-28Vdc
  - **Input Current (Max):** 8mA
  - **Start Voltage:** 15V
  - **Stop Voltage:** 5V
  - **Pulse Frequency (Max):** 100Hz, 50% Duty Ratio (5ms ON and 5ms OFF)

## 2.5 Environment

- **North America:** -25 to 70 degrees Celsius, 90% RH, non-condensing

# Chapter 3: Appearance and Dimensions

**Physical Size:** 6.3" x 3.5" x 1.27" (159.9mm x 90mm x 32.2mm)

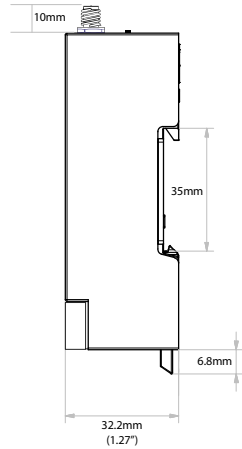
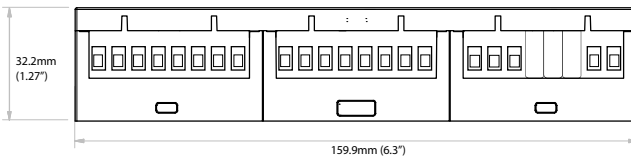
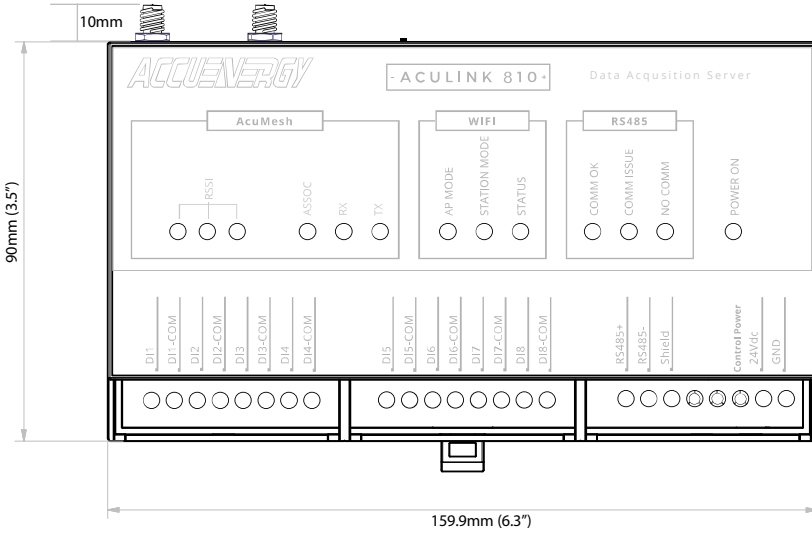

# Chapter 4: Installation

## 4.1 Installation Checklist

The following materials are required for the AcuLink 810 installation:

- AcuLink 810 Data Acquisition Server
- Ethernet Cat 5 Cable (Required for LAN or direct computer to AcuLink 810 connection)
- Power Supply (24V)
- WiFi Antenna

### 4.1.1 Optional Hardware:

- Additional Modbus RTU devices
- 2 wire Modbus/RS485 connection

### 4.1.2 LAN Information

- Ethernet 10/100MB connection point (router/switch)
- IP address and subnet mask (Check with system administrator)
- Gateway Address (Check with system administrator)
- DNS server address (Check with system administrator)

### 4.1.3 Installation Safety Requirements and Considerations

- Field wiring must have a rating of higher than 70°C; Stranded wiring
- Intended for indoor use
- Altitude: 2000 meters
- Overvoltage Category: II
- Pollution Degree: 2

### 4.2 Powering the unit

- The power supply of the AcuLink 810 is rated for 24Vdc.

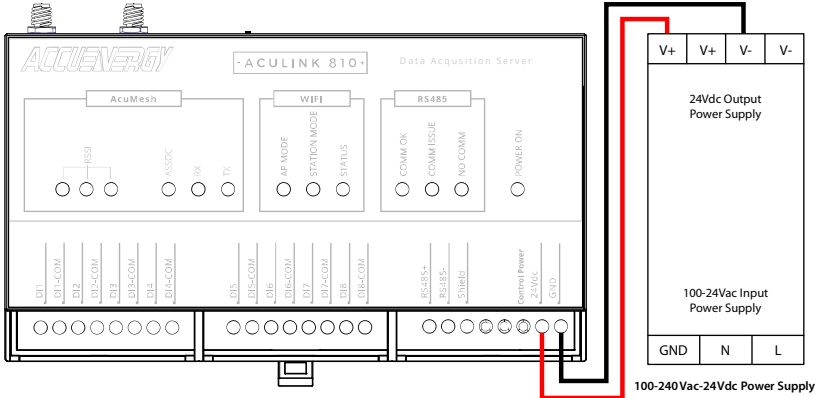

## Chapter 5: LED Description

There are a total of 13 LEDs on the AcuLink 810 data acquisition server and each represents different functions pertaining to the unit.

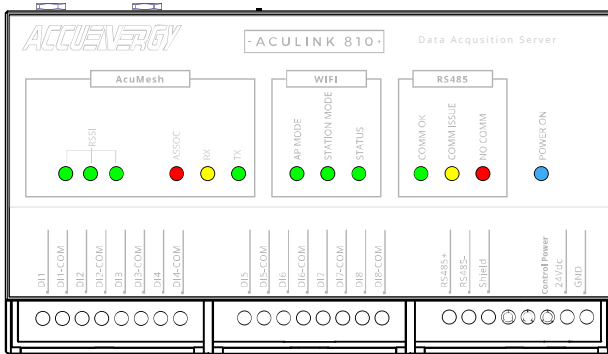

With the exception of the blue power LED, the remaining LEDs can be divided into three groups:

### 5.1 AcuMesh LEDs

The AcuMesh has a total of six LEDs which are related to the AcuMesh status.

#### RSSI

- There are three RSSI LEDs which indicate the signal strength of the incoming signal.
  - 3 LEDs would indicate Excellent signal strength
  - 2 LEDs would indicate good signal strength
  - 1 LED would indicate poor signal strength
  - 0 LED would indicate bad signal strength

#### ASSOC

- Indicates that the transceiver is powered on or it is communicating. The Red LED is ON when powered, and briefly ON or flashing during RF transmission.

#### RX

- Indicates that the transceiver is receiving data.

#### TX

- Indicates that the transceiver is transmitting data.

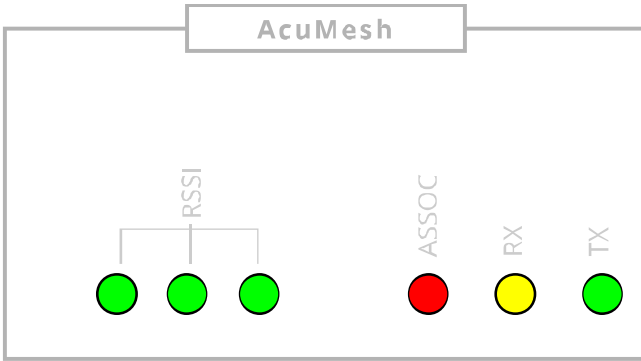

## 5.2 WiFi LEDs

The WiFi has a total of 3 LEDs which are related to the WiFi status.

### AP MODE

- When ON Indicates that the WiFi is working in Access Point Mode.

### STATION MODE

- When ON indicates that the WiFi is working in Station Mode.

### STATUS

- When ON indicates that the WiFi is working and functioning properly.

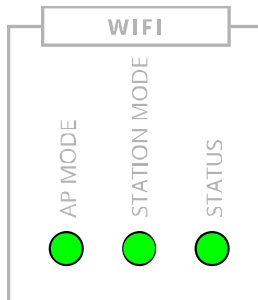

### 5.3 RS485 LEDs

The RS485 has a total of 3 LEDs which are related to the RS485 status.

#### COMM OK

- When ON indicates that all RS485 and USB devices in RS485 network are online and is represented by a green LED.

#### COMM ISSUE

- When ON indicates that some of the devices in the RS485 network are offline and is represented by a yellow LED

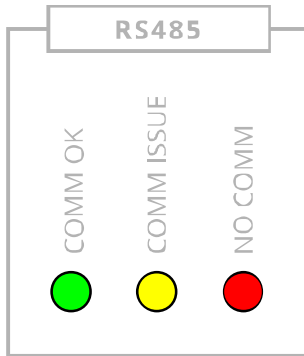

#### NO COMM

- When ON indicates that all RS485 devices in the RS485 network are offline and is represented by a red LED



# Chapter 6: Initializing the AcuLink 810

The AcuLink 810 has a web interface that users can access to configure the gateway settings and view device data. The AcuLink 810 gateway has two Ethernet ports and also supports communication via WiFi.

The default IP addresses and default modes are:

**Ethernet 1:** 192.168.8.101

**Ethernet 2:** DHCP

**WiFi:** Access Point Mode

The following will outline the methods on how to initially access the data acquisition server's web interface using the different methods.

## 6.1 Accessing the AcuLink 810 Web Interface

### 6.1.1 Method 1 - Direct Connection via Ethernet

For the direct connection method, there must be an Ethernet connection from the Ethernet 1 port on the AcuLink and a computer.

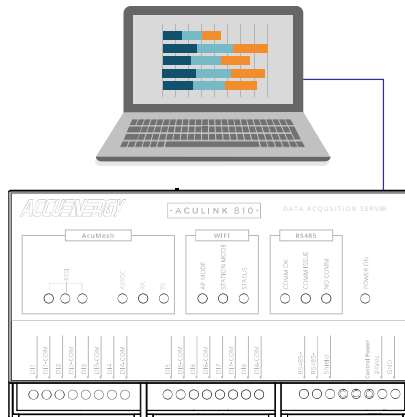

Next in order to access the web interface, the computer's IP address must be configured with-in the same subnet as the AcuLink Ethernet 1 IP address. The Ethernet 1 port has a default IP address of 192.168.8.101.

The following outlines how to change the computer's IP:

- Start by accessing the control panel of the computer and select **Network and Internet**.



- Select **Network and Sharing Center**.

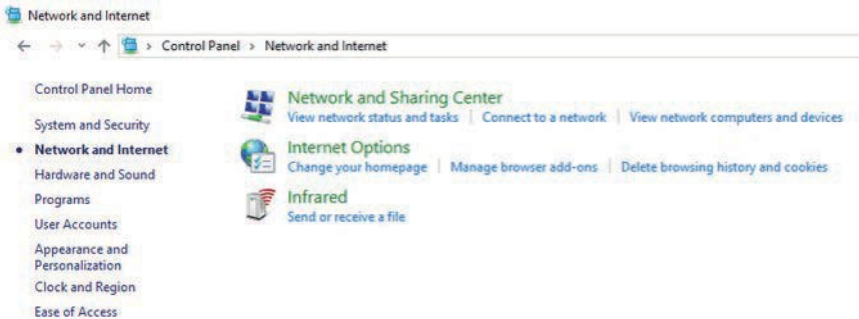

- On the left panel of the screen, select **Change adapter settings**.

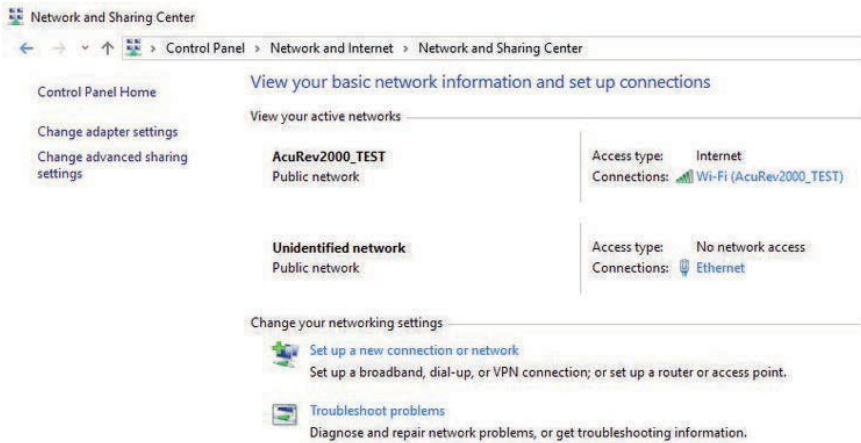

- Double click on **Ethernet**, or right click on **Ethernet** and select **Properties**.

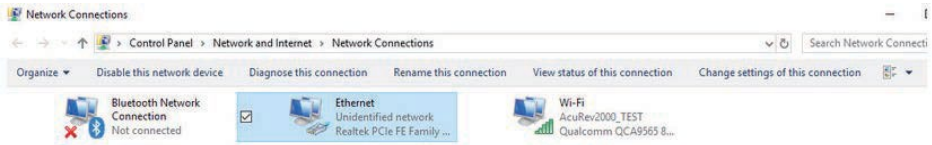

- The following page will open, click on **Properties**.

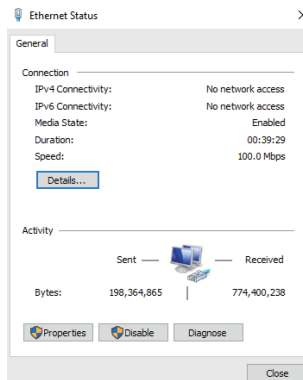

- The following page will open, select **Internet Protocol Version 4 (TCP/IPv4)** and click on **Properties**.

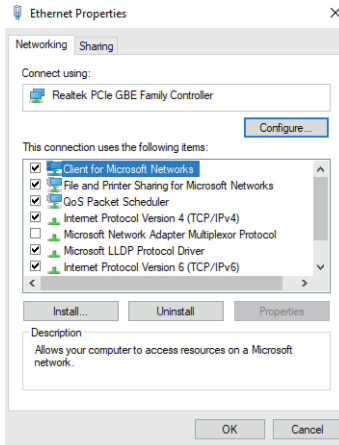

- Select the option **Use the following IP address:** and change the IP address of the computer. The AcuLink 810 Ethernet 1 address is 192.168.8.101, the computer's IP will need to be within the same subnet. The IP of the computer can be 192.168.8.xxx, where xxx can be any number ranging from 1-254. For the example an IP address of 192.168.8.10 is used.

**NOTE:** The computer's IP address and the AcuLink 810 Ethernet 1 IP address cannot be the same.

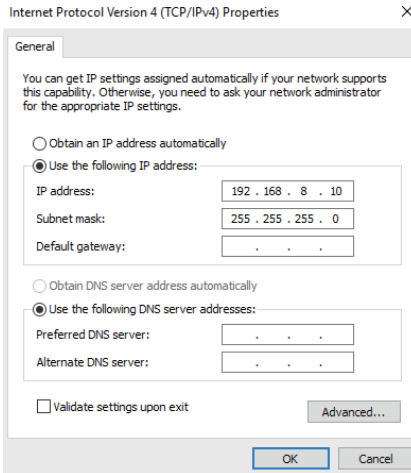

- Once all settings are complete click on **OK** to confirm the network changes.
- Then open up an internet browser and type in the AcuLink 810 IP address of **192.168.8.101**, a login screen will be prompted.
- To login to the web interface, a username and password must be entered.
  - The default username is **admin**, and the default password is also **admin**.

**NOTE:** The recommended internet browsers to access the 810's web interface are Google Chrome, or FireFox.



The screenshot shows the login interface for the AccuEnergy AcuLink 810 Data Acquisition Server. At the top is the AccuEnergy logo, followed by the text "AcuLink 810 Data Acquisition Server". Below this is a horizontal line and the text "Sign in to continue". There are two input fields: "User Name" with the text "admin" entered, and "Password" with five dots representing a masked password. At the bottom is a blue "Sign In" button.

### 6.1.2 Method 2 - Using WiFi to connect to the data acquisition server's Web Interface

The web interface of the AcuLink can be accessed by WiFi. Ensure that the WiFi antenna is installed on the unit.

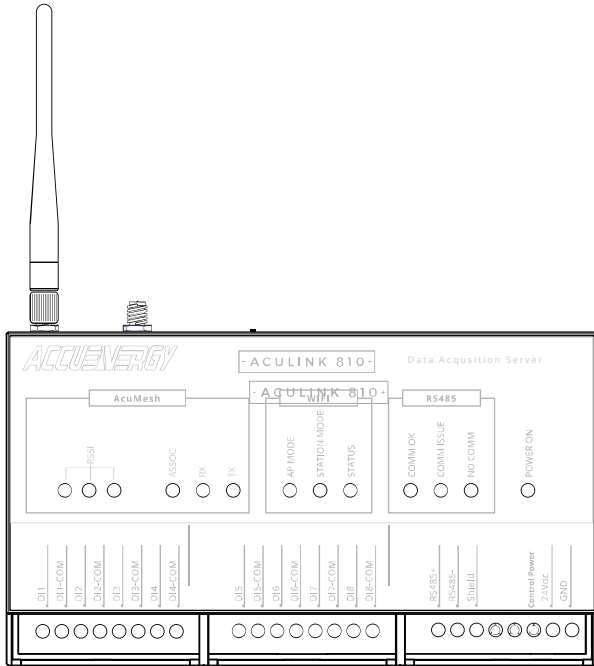

By default the AcuLink 810 has its WiFi mode set as AP (Access Point) mode, where the AcuLink 810 acts as a wireless access point allowing other wireless devices to connect and access the gateway.

To connect to the AcuLink via AP mode, search for the SSID in the list of available wireless networks.

The SSID will be by default **AcuLink810-WiFi-S8Pxxxxxxxx**, where the **S8Pxxxxxxxx** is the unique serial number of the AcuLink gateway. The serial number of the AcuLink can be found on the side of the unit. The password for the network is **accuenergy**.

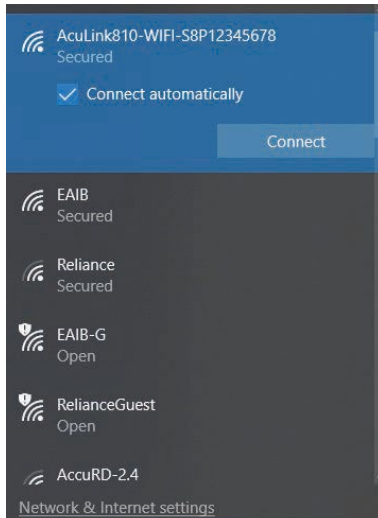

Once connected to the gateway's wireless network, open up an internet browser and enter in the IP address **192.168.100.1**. The web server login screen will be prompted.

- To login to the web interface, a username and password must be entered.
  - The default username is **admin**, and the default password is also **admin**.

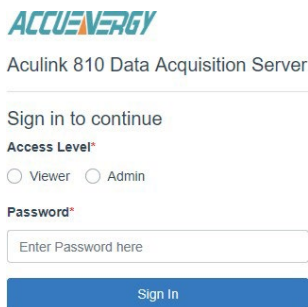

**ACCUENERGY**  
AcuLink 810 Data Acquisition Server

Sign in to continue

**Access Level\***

Viewer  Admin

**Password\***

Enter Password here

Sign In

## 6.2 Dashboard

When logged in to the AcuLink 810 web interface, users are directed to the **Dashboard**. The dashboard provides the user with a summary of all the Offline Devices as well as the Devices in Alarm. Under the alarms section of the dashboard the interface includes the **Up Since** time, which lets the user know the time the 810 was powered on or rebooted.

The tabs on the top of the interface allows users to access different settings within the gateway.

The header at the very top of the page allows users to view the time and date of the AcuLink 810. The footer on the bottom of the web page includes links to the Accuenergy website for further information and details.

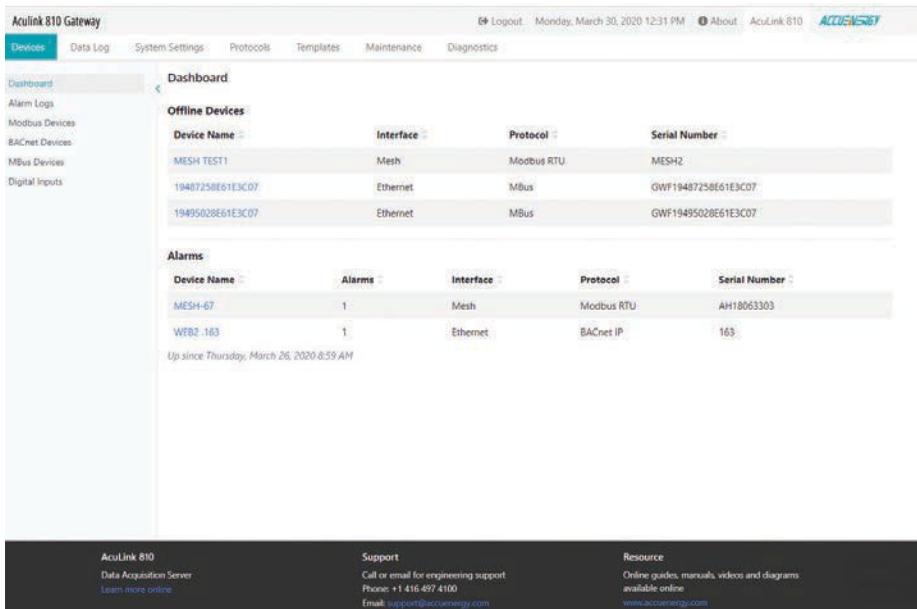

### 6.2.1 About Page

Users can check the AcuLink 810 Device Information on the **About** page located on the top right corner of the dashboard. From the About page users are provided with an overview of the AcuLink 810 model number, serial number, Hardware and Firmware versions, and the Ethernet/WiFi MAX addresses.



Users have the option to enter a Name, Location, and Description for the gateway. Once configured click on **Save**.

AcuLink 810 Gateway Logout Thursday, April 2, 2020 6:21 AM About AcuLink 810 

**Device Information**

Setting	Value
Name	<input type="text" value="AcuLink 810 Gateway"/> <small>Maximum 40 characters</small>
Location	<input type="text" value="Enter Location"/> <small>Maximum 20 characters</small>
Description	<input type="text" value="Enter Description"/> <small>Maximum 40 characters</small>
Model	AcuLink810-X
Serial Number	SBP18120083
Hardware Version	v1.05
Firmware Version	v1.06
Last Updated	2020-04-01 12:38:01
Ethernet 1 MAC Address	
Ethernet 2 MAC Address	
WiFi MAC Address	

# Chapter 7: Device Templates

The AcuLink 810 requires a device Template in order to communicate and read data from any Modbus and any BACnet device. The Modbus template supports different Modbus function codes including read coil (Function code 01), read discrete input (Function Code 02), read holding registers (Function Code 03), and read Input registers (Function Code 4). The Modbus device template also supports several data type formats to read different types of Modbus parameters.

In order for the AcuLink 810 to read device data using either Modbus or BACnet protocols a device template will first need to be installed or created. Within the AcuLink 810 web interface, users can create, modify and convert their own templates from different formats (csv, EPICS, etc). Users can view the template configuration from the **Templates** tab, from there they can create/add both Modbus and BACnet templates.

The following sections explain how to create Modbus and BACnet templates for the AcuLink 810.

## 7.1 Modbus Templates

Modbus Templates are used in the AcuLink 810 to correctly read the metering data from Accuenergy and third party Modbus devices. Before a device can be added to the gateway a Modbus template for the device must first be uploaded and installed onto the unit.

In the Modbus templates page users can view the templates and the version number currently installed on to the AcuLink under the **Installed** tab.

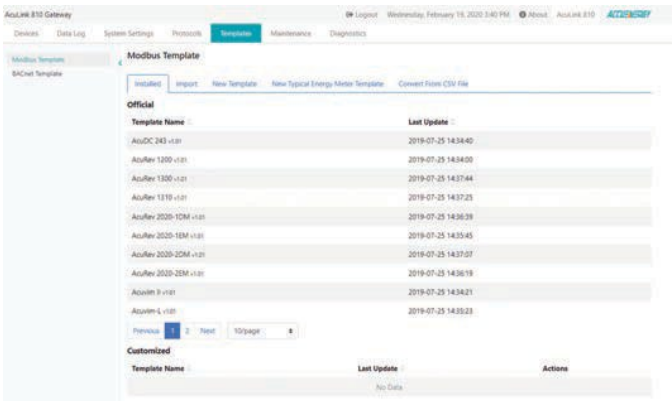

## Customized Templates

If there are customized templates on the AcuLink 810 users have the following action buttons available.

### Actions



The icons have the following meaning:



The first icon allows users to download the .def template file.



The second icon allows users to create a new template based on that existing template.



The third icon allows users to create a new version based on that existing template.



The fourth icon allows users to delete the template.

### 7.1.1 Import Template

To upload a new device template click on the **Import** tab. All Accuenergy device templates can be found in the remote update section of the page. In order to use the remote upload function, users must ensure they have sufficient connection to the Internet.

For third party device templates, users can upload and install templates manually.

**NOTE:** Data log and alarm monitoring configurations will be lost after updating an existing device template.

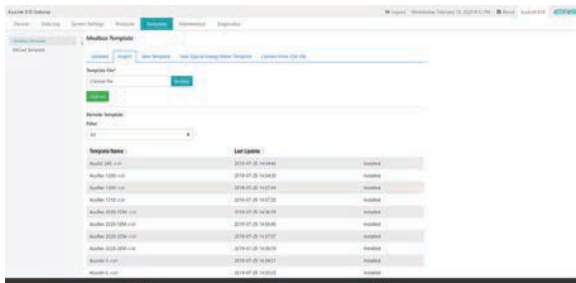

## 7.1.2 New Template

Under the **New Template** tab users can create and build their own Modbus template. There are four steps required in building the template which includes 1) Device Info, 2) Create Block, 3) Create Parameter, and 4) Save

### 1. Device Information

Users will need to enter in a Device Model, which must be a unique model name. They will also need to enter in a device version that must also be unique.

Click on **Save Device Info** once the information has been entered correctly.

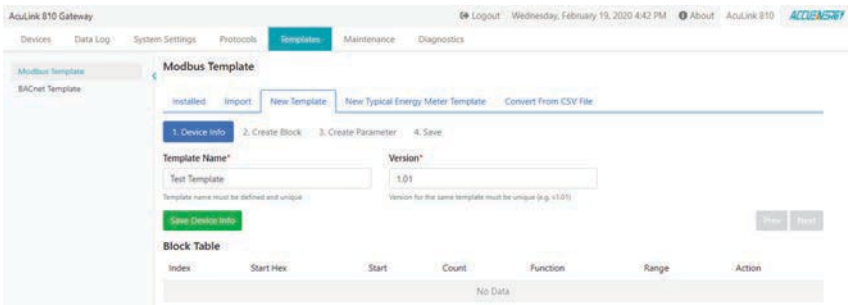

### 2. Create Block

The second step includes creating the register blocks for the Modbus Device.

- Select the Modbus Function Code of the register block (i.e. Read Holding Registers, Read Discrete Input, Read Coils, read Input Registers)
- Enter in the starting address of the register block, this address must be in hexadecimal.
- Enter the count, i.e. the number of registers in this block.

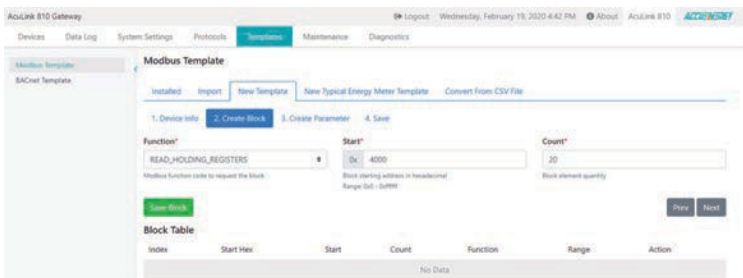

Once all register block information is configured correctly click on Save Block. The saved block will then appear in the Block Table at the bottom portion of the web page. In the Block Table users have the option to edit, delete or view the details of the register block created.

AcuLink B10 Gateway

Logout Wednesday, February 19, 2020 4:44 PM About AcuLink B10

Devices Data Log System Settings Protocols **Templates** Maintenance Diagnostics

Modbus Template

Installed Import **New Template** New Typical Energy Meter Template Convert From CSV File

1. Device Info 2. **Create Block** 3. Create Parameter 4. Save

Function\* READ\_HOLDING\_REGISTERS Start\* 0x 4000 Count\* 20

Block starting address in hexadecimal Range (dd - dddddd)

Block element quantity

Save Block Prev Next

**Block Table**

Index	Start Hex	Start	Count	Function	Range	Action
0	0x4000	16384	20	READ_HOLDING_REGISTERS	Block 0: 0x4000 - 0x4012 : 20	Details Edit Delete

- If there are multiple register blocks for the Device users can continue creating them. Once all register blocks are complete click on **Next** to continue.

### 3. Create Parameter

The third step includes adding the parameters required to the template.

Users will need to select what block the parameter resides in and also create a display tab to view the parameter once the template is complete.

**Block:** Select the block for the parameter in the drop down menu.

**Select display tab(s):** In this field enter in a tab that you wish to create and can press enter to create the tab. For example this tab could be named Energy, or Real time data. This tab is where users can find the parameter they have created under once the template is complete. After the tab is created it can be selected from the drop down menu. Users can create multiple tabs in the same manner.

**Label:** Enter in a label for the parameter, i.e. voltage, current, temperature, etc.

**Address:** Enter in the Modbus register address for the parameter. This address must be hexadecimal.

**Multiplier:** Users can input a multiplier on the parameter.

**Post Label:** Users can define a post label for the parameter. The post label is used whenever the device data is downloaded or sent to an external server, where the csv file that is generated would have the post label as the header in the file.

**Data Format:** Select the data format for the parameter, some typical data types include Int, float, hex, etc.

**Byte Order:** The byte order for the parameter can be specified, i.e. some devices require the byte order to be swapped in order to read the parameter correctly.

**Unit (optional):** Users can enter in the preferred unit for the parameter, this setting is optional.

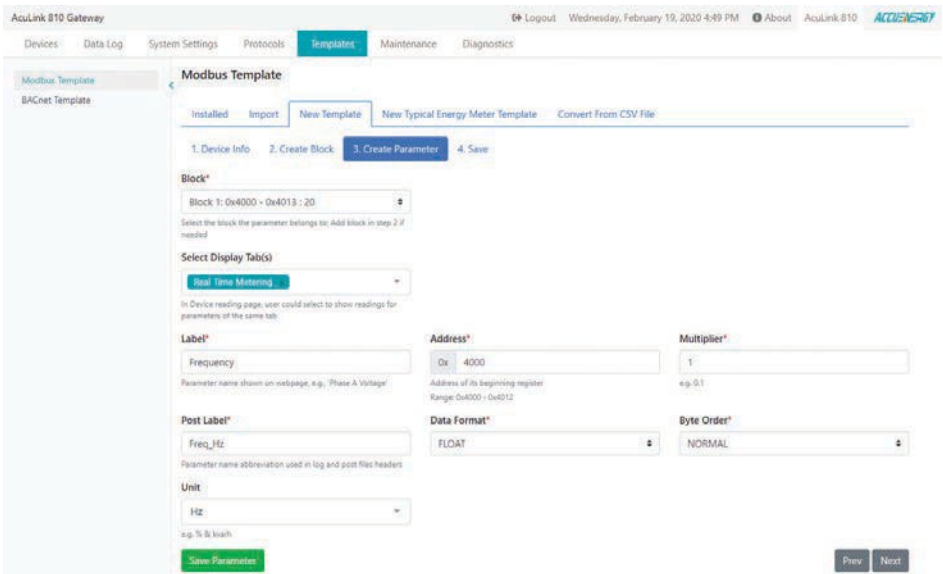

- Once all parameter settings are configured click on **Save Parameter**. After the parameter is saved users can view the parameter in the Block Table below under the Detail tab. Under the **detail** tab users can edit the existing parameter by selecting the **Edit** button, and can delete the existing parameter by selecting the **Delete** button.

Save Parameter

Prev

Next

## Block Table

Index	Start Hex	Start	Count	Function	Range	Action		
0	0x4000	16384	20	READ_HOLDING_REGISTERS	Block 0: 0x4000 - 0x4013 : 20	Detail	Edit	Delete

Index	Tab	Label	Address Hex	Address	Multiplier	Post Label	Unit	Action
0	Real Time Metering	Frequency	0x4000	16384	1	Freq_Hz	Hz	Edit Delete

Once Users have added all required parameters to the Modbus Template click on **Next**.

#### 4. Save

The last step is saving the device template. Users can review the Block Table and modify any parameters before saving the template. They can also click on **Prev** button to go back and alter any blocks or parameters as needed.

AccuLink 810 Gateway Logout Wednesday, February 19, 2020 4:59 PM About AccuLink 810

Devices Data Log System Settings Protocols **Templates** Maintenance Diagnostics

Modbus Template Installed Import New Template New Typical Energy Meter Template Convert From CSV File

BACnet Template

1. Device Info 2. Create Block 3. Create Parameter **4. Save**

Configuration completed!

Proceed to save device only if model name and version number have been defined.

If you leave or refresh the page without saving it to database, all locally saved configurations will be discarded.

Create Template Prev Next

**Block Table**

Index	Start Hex	Start	Count	Function	Range	Action		
0	0x4000	16384	20	READ_HOLDING_REGISTERS	Block 0: 0x4000 - 0x4013 : 20	Detail	Edit	Delete

Index	Tab	Label	Address Hex	Address	Multiplier	Post Label	Unit	Action
0	Real Time Metering	Frequency	0x4000	16384	1	Freq_Hz	Hz	Edit Delete
1	Real Time Metering	Phase A Voltage	0x4002	16386	1	Va_V	V	Edit Delete
2	Real Time Metering	Phase B Voltage	0x4004	16388	1	Vb_V	V	Edit Delete
3	Real Time Metering	Phase C Voltage	0x4006	16390	1	Vc_V	V	Edit Delete
4	Real Time Metering	Average Voltage	0x4008	16392	1	Vavg_V	V	Edit Delete
5	Real Time Metering	Line Voltage AB	0x400a	16394	1	Vab_V	V	Edit Delete
6	Real Time Metering	Line Voltage BC	0x400c	16396	1	Vbc_V	V	Edit Delete

- After reviewing all details of the Modbus Template click on **Create Template**, users will be redirected to the **Installed** tab of the Modbus Template page where the newly created template will be seen under the **Customized Templates** at the bottom of the page.

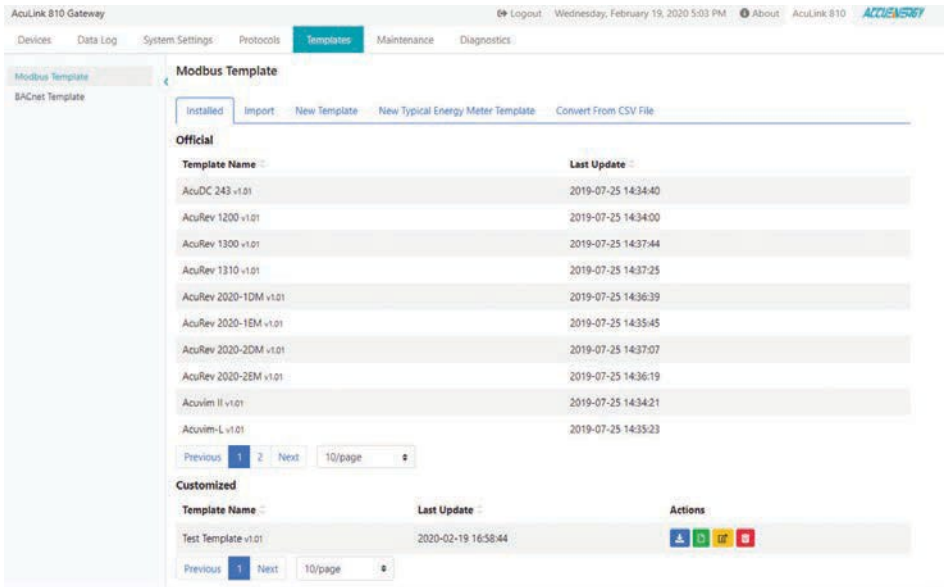

## 7.1.3 Typical Energy Meter Template

The Typical Energy Meter Template allows users to create a Modbus Template for their third party device and have the ability to post data to our cloud based energy management software **AcuCloud**. To create a device template that allows third party devices to post data to the AcuCloud software click on the **Typical Energy Meter Template** tab.

This page will have the following sections:

### 1. Device

Under the device section users can enter in the Template name and the version number. Once all device settings are configured click on **Save Device Info**.

### 2. Block

Users can create the required register blocks for their device, where the function, starting address in hex, and the register count must be specified. Once a block is created click on **Save Block**, users can create multiple blocks for the device template. All created blocks will appear in the block table located further down the page.



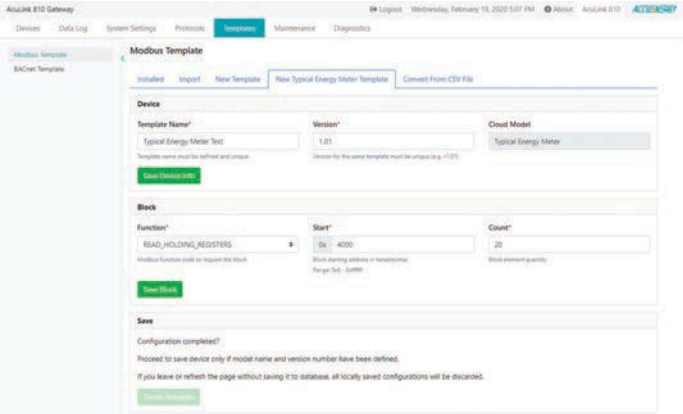

### 3. Parameter Table

The parameter table has all the parameters that are supported on our cloud based software. Users can find and locate the same parameters within the table that are supported on their third party device and configure it to their template by clicking on the **Edit** button next to that parameter.

On the edit page users will need to select the block, starting address, multiplier, data type and byte order of the parameter.

After these settings are configured click on **Save**.

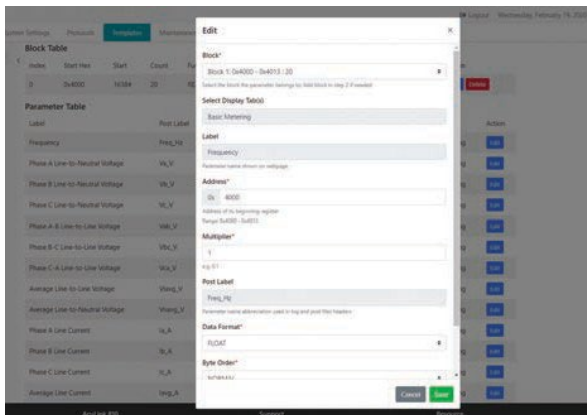

When all desired parameters have been configured and added to the template, click on the Create **Template** button.

Users will be redirected to the **Installed** tab on the Modbus Template page, where the newly created Typical Energy Meter Template will be seen under the **Customized** templates at the bottom of the page.

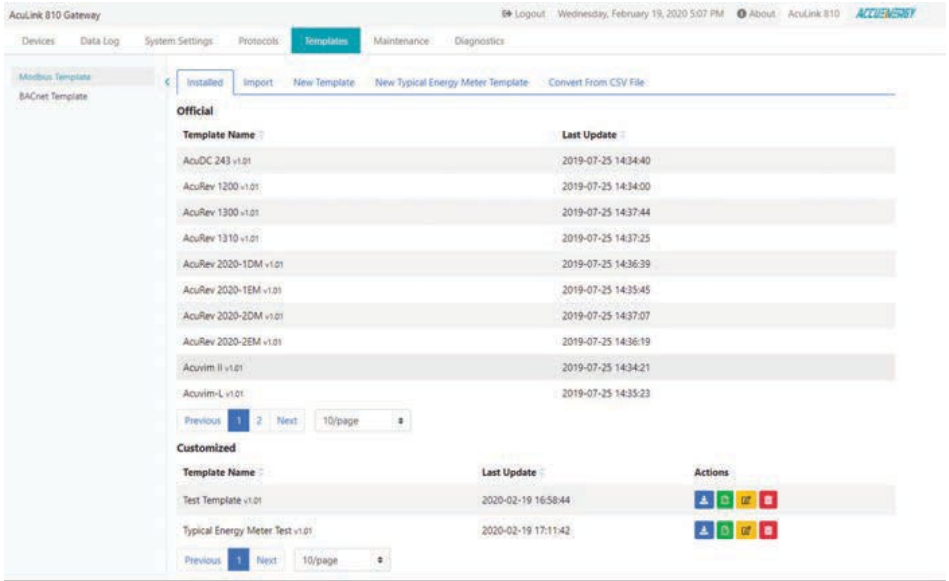

## 7.1.4 Creating Template from CSV

The AcuLink 810 supports a CSV to Modbus template converter directly from its web interface. To access this converter, click on the Convert From CSV File tab on the Modbus Template page.

Users can enter in the desired name and version number for the Template.

Under the CSV file section, users will need to upload a CSV file containing all device register information for their device.

A sample CSV file can be downloaded directly from the interface where users can edit and use it to build their own file. The CSV file must be in the same format as the sample file in order to successfully convert the file into a template file.

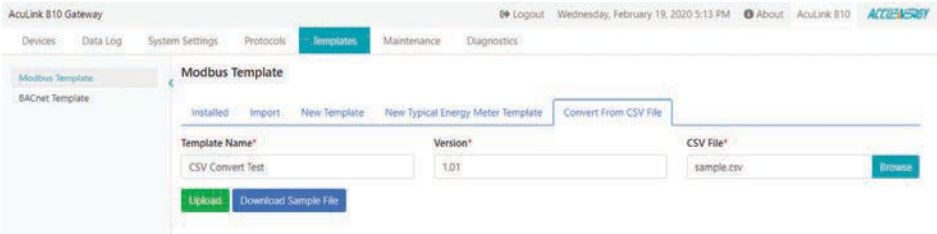

The sample CSV file:

	A	B	C	D	E	F	G	H	I	J	K
1	label	address	dataFormat	byteOrder	slope	postLabel	cloudEnabled	units	block	tab	
2	Frequency	16384	FLOAT	NORMAL	1	Freq_Hz	FALSE	Hz	16384(10)	Basic Metering	
3	Phase A Line-to-Neutral Voltage	16386	FLOAT	NORMAL	1	V1	TRUE	V	16384(10)	Basic Metering	
4	Phase B Line-to-Neutral Voltage	16388	FLOAT	NORMAL	1	V2	TRUE	V	16384(10)	Basic Metering	
5	Phase C Line-to-Neutral Voltage	16390	FLOAT	NORMAL	1	V3	TRUE	V	16384(10)	Basic Metering	
6	Average Line-to-Neutral Voltage	16392	FLOAT	NORMAL	1	Vnavg_V	TRUE	V	16384(10)	Basic Metering	
7	System Active Power Demand	16450	FLOAT	NORMAL	0.001	DMD_P_kwh	TRUE	kWh	16450(6)	Demand	
8	System Reactive Power Demand	16452	FLOAT	NORMAL	0.001	DMD_Q_kvarh	TRUE	kvarh	16450(6)	Demand	
9	System Apparent Power Demand	16454	FLOAT	NORMAL	0.001	DMD_S_kVAh	TRUE	kVAh	16450(6)	Demand	
10	System Import Active Energy	16456	UINT32	NORMAL	0.1	EP_IMP_kWh	TRUE	kWh	16456(18)	Energy	
11	System Export Active Energy	16458	UINT32	NORMAL	0.1	EP_EXP_kWh	TRUE	kWh	16456(18)	Energy	
12	System Import Reactive Energy	16460	UINT32	NORMAL	0.1	EQ_IMP_kvarh	TRUE	kvarh	16456(18)	Energy	
13	System Export Reactive Energy	16462	UINT32	NORMAL	0.1	EQ_EXP_kvarh	TRUE	kvarh	16456(18)	Energy	
14	System Total Active Energy	16464	UINT32	NORMAL	0.1	EP_TOTAL_kWh	TRUE	kWh	16456(18)	Energy	
15	System Net Active Energy	16466	INT32	NORMAL	0.1	EP_NET_kWh	TRUE	kWh	16456(18)	Energy	
16	System Total Reactive Energy	16468	UINT32	NORMAL	0.1	EQ_TOTAL_kvarh	TRUE	kvarh	16456(18)	Energy	
17	System Net Reactive Energy	16470	INT32	NORMAL	0.1	EQ_NET_kvarh	TRUE	kvarh	16456(18)	Energy	
18	System Apparent Energy	16472	UINT32	NORMAL	0.1	ES_kVAh	TRUE	kVAh	16456(18)	Energy	
19	Phase A Import Active Energy	17952	UINT32	NORMAL	0.1	EPa_IMP_kWh	FALSE	kWh	17952(30)	Energy	
20	Phase A Export Active Energy	17954	UINT32	NORMAL	0.1	EPa_EXP_kWh	FALSE	kWh	17952(30)	Energy	
21	Phase B Import Active Energy	17956	UINT32	NORMAL	0.1	EPb_IMP_kWh	FALSE	kWh	17952(30)	Energy	
22	Phase B Export Active Energy	17958	UINT32	NORMAL	0.1	EPb_EXP_kWh	FALSE	kWh	17952(30)	Energy	
23	Phase C Import Active Energy	17960	UINT32	NORMAL	0.1	EPc_IMP_kWh	FALSE	kWh	17952(30)	Energy	
24	Phase C Export Active Energy	17962	UINT32	NORMAL	0.1	EPc_EXP_kWh	FALSE	kWh	17952(30)	Energy	
25	Phase A Import Reactive Energy	17964	UINT32	NORMAL	0.1	EQa_IMP_kvarh	FALSE	kvarh	17952(30)	Energy	
26	Phase A Export Reactive Energy	17966	UINT32	NORMAL	0.1	EQa_EXP_kvarh	FALSE	kvarh	17952(30)	Energy	
27	Phase B Import Reactive Energy	17968	UINT32	NORMAL	0.1	EQb_IMP_kvarh	FALSE	kvarh	17952(30)	Energy	
28	Phase B Export Reactive Energy	17970	UINT32	NORMAL	0.1	EQb_EXP_kvarh	FALSE	kvarh	17952(30)	Energy	
29	Phase C Import Reactive Energy	17972	UINT32	NORMAL	0.1	EQc_IMP_kvarh	FALSE	kvarh	17952(30)	Energy	
30	Phase C Export Reactive Energy	17974	UINT32	NORMAL	0.1	EQc_EXP_kvarh	FALSE	kvarh	17952(30)	Energy	
31	Phase A Apparent Energy	17976	UINT32	NORMAL	0.1	ESa_kVAh	FALSE	kVAh	17952(30)	Energy	
32	Phase B Apparent Energy	17978	UINT32	NORMAL	0.1	ESb_kVAh	FALSE	kVAh	17952(30)	Energy	
33	Phase C Apparent Energy	17980	UINT32	NORMAL	0.1	ESc_kVAh	FALSE	kVAh	17952(30)	Energy	
34											

Once all information and CSV file have been uploaded click on the **Upload** button.

Users will be redirected to the **Installed** tab on the Modbus Template page where the newly converted Modbus template will be seen under the **Customized** templates located at the bottom of the page.

The screenshot shows the 'AcuLink 810 Gateway' interface with the 'Templates' tab selected. The page is divided into two sections: 'Official' and 'Customized'.

**Official Templates:**

Template Name	Last Update
AcuDC 243 v1.01	2019-07-25 14:34:40
AcuRev 1200 v1.01	2019-07-25 14:34:00
AcuRev 1300 v1.01	2019-07-25 14:37:44
AcuRev 1310 v1.01	2019-07-25 14:37:25
AcuRev 2020-1DM v1.01	2019-07-25 14:36:39
AcuRev 2020-1EM v1.01	2019-07-25 14:35:45
AcuRev 2020-2DM v1.01	2019-07-25 14:37:07
AcuRev 2020-2EM v1.01	2019-07-25 14:36:19
AcuWim II v1.01	2019-07-25 14:34:21
AcuWim-L v1.01	2019-07-25 14:35:23

**Customized Templates:**

Template Name	Last Update	Actions
CSV Convert Test v1.01	2020-02-19 17:16:34	[Download] [Install] [Delete]
Test Template v1.01	2020-02-19 16:58:44	[Download] [Install] [Delete]
Typical Energy Meter Test v1.01	2020-02-19 17:11:42	[Download] [Install] [Delete]

## 7.2 BACnet Template

BACnet Templates are used in the AcuLink 810 to correctly read the metering data from Accuenergy and third party BACnet devices. Before a device can be added to the gateway a BACnet template for the device must first be uploaded and installed onto the unit.

On the Templates page select **BACnet Template**.

In the BACnet templates page users can view the templates and the version number currently installed on to the AcuLink under the **Installed tab**.

## 7.2.1 Import Template

To upload a new device template click on the **Import** tab. Users can upload a BACnet template manually or can download templates from our remote server. To import a template manually users must ensure that the device template is in **.def** format as no other formats are accepted on the AcuLink 810.

Alternatively users can download a BACnet template from our remote server by clicking on the **Check** button. A template can be installed directly from our server to the AcuLink 810.

Template Name	Last Update	Install
1 v1	2019-11-08 16:39:26	Install
AcuRev 1310 BACnet v0.01	2019-07-19 10:08:38	Installed
AcuVim II BACnet v0.01	2019-07-19 10:07:57	Installed
EPICS TEST v0.03	2019-07-26 17:01:20	Install
Test v1	2019-09-25 11:20:03	Install
Test1 v2	2019-07-19 16:04:02	Install
Test2 v0.03	2019-07-19 15:21:53	Install
Test3 v0.02	2019-07-19 16:02:05	Install

**NOTE:** If users are updating or editing an existing template the Data log and alarm monitoring configurations will be lost after updating an existing device template.

### 7.2.2 Convert from EPICS File

The AcuLink 810 supports a template converter that convert the EPICS file from BACnet devices into a .def BACnet template supported on the AcuLink. Under the **Convert from EPICS** File tab users can enter in the template name, version number and upload the EPICS file.

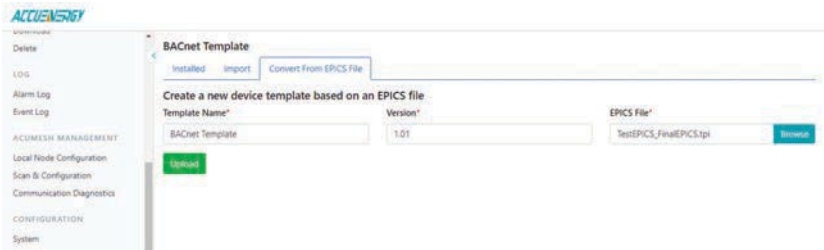

Once the name, version and EPICS file has been uploaded users can click on **Upload**. Users will be able to configure and specify which parameter they want to include in the BACnet template, once the parameters are configured click on **Save** at the bottom of the page.

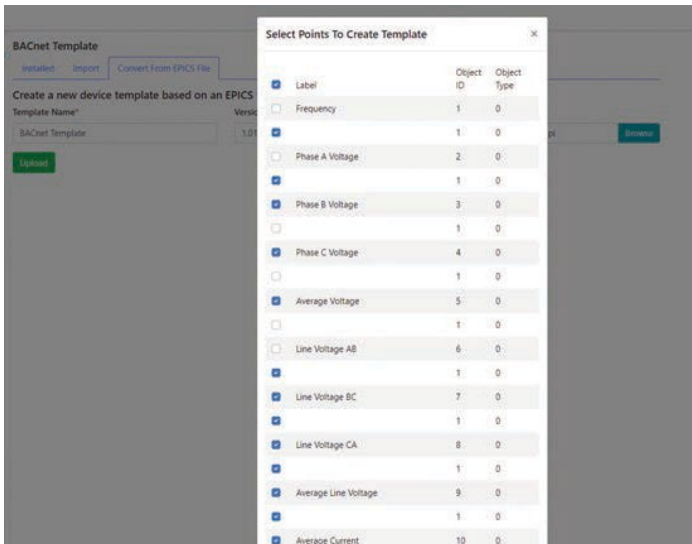

Users will be redirected to the **Installed** tab in the BACnet Template page where the newly converted template file will be seen under the **Customized** templates located at the bottom of the page.

The screenshot displays the ACCUENERGY BACnet Template management interface. The interface is divided into two main sections: **Official** and **Customized**.

**Official Templates:**

Template Name	Last Update
AcuRev 1310 BACnet v0.01	2019-07-19 10:08:38
AcuVim II BACnet v0.01	2019-07-19 10:07:57

**Customized Templates:**

Template Name	Last Update	Actions
BACnet Template v1.01	2019-12-19 11:59:14	[Download] [Delete]

The interface also includes a sidebar with navigation options such as 'Delete', 'LOG', 'Alarm Log', 'Event Log', 'ACUMESH MANAGEMENT', 'Local Node Configuration', 'Scan & Configuration', 'Communication Diagnostics', 'CONFIGURATION', 'System', 'Date & Time', 'Network', 'Email', and 'Alarm Notification'. The main content area has tabs for 'Installed', 'Import', and 'Convert From EPICS File'. Navigation controls like 'Previous', 'Next', and '10/page' are visible below the template lists.

# Chapter 8: System Settings

## 8.1 Network

All network related configurations can be found on the **Network** page under the **System Status** tab. Users can configure all Ethernet (ports 1 & 2), WiFi, DNS, and RSTP configurations from this page.

### 8.1.1 Ethernet

There are two Ethernet ports on the AcuLink 810, by default Ethernet port 1 has a static IP where as Ethernet port 2 is configured for DHCP.

Default Ethernet port 1 settings:

- IP Address - 192.168.8.101
- Submask - 255.255.255.0
- Gateway - 192.168.8.101

Default Ethernet port 2 settings:

- DHCP enabled

The **Interface Status** on the network page lets users know what is connected or disconnected, for example the image below shows both interface status as **Connected** which indicates that both Ethernet 1 and Ethernet 2 have an Ethernet cable connected to the port.

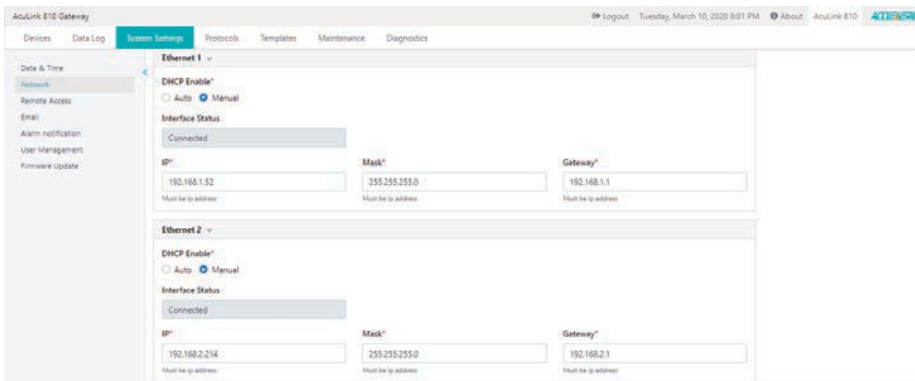



### 8.1.2 WiFi

There are two WiFi modes in the AcuLink 810, Access point and station.

**NOTE:** When using WiFi ensure that the provided antenna is installed on the AcuLink 810 unit.

**Access Point Mode** - Is the default WiFi configuration for AcuLink 810, where the gateway will act as a wireless access point and will allow other wireless devices to connect and access the AcuLink 810.

- In Access Point mode, users can configure the SSID, Network Key and IP of the AcuLink 810 as well as the DHCP DNS servers.
- The default AP mode settings:
  - SSID - **AcuLink810-WiFi-SERIAL#810**
  - Network Key - **accuenergy**
  - IP - **192.168.100.1**

**NOTE:** For steps on how to access the web interface via WiFi AP mode refer to chapter 6 section 6.1.2.

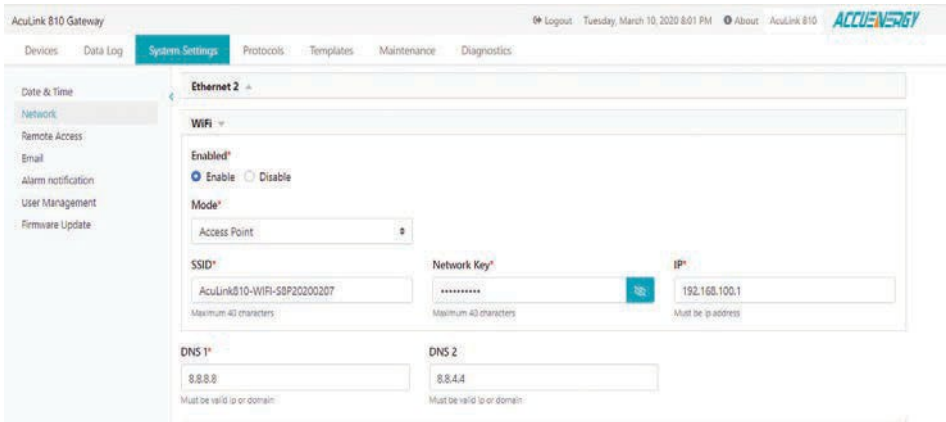

**Station Mode:** The AcuLink 810 will behave like a wireless client and bridge to another wireless network that is available.

- In Station mode, users can select the Wireless network to connect to in the SSID drop down menu. Once the desired wireless network is configured enter the Network Key for the wireless network that the AcuLink 810 will bridge to.

## AcuLink 810 Data Acquisition Server

- Users can configure a static WiFi IP by manually entering in the IP, submask, and gateway of the WiFi network. Alternatively the WiFi can be configured for DHCP where the IP, sub-mask, and gateway of the WiFi network is automatically assigned to the AcuLink 810.

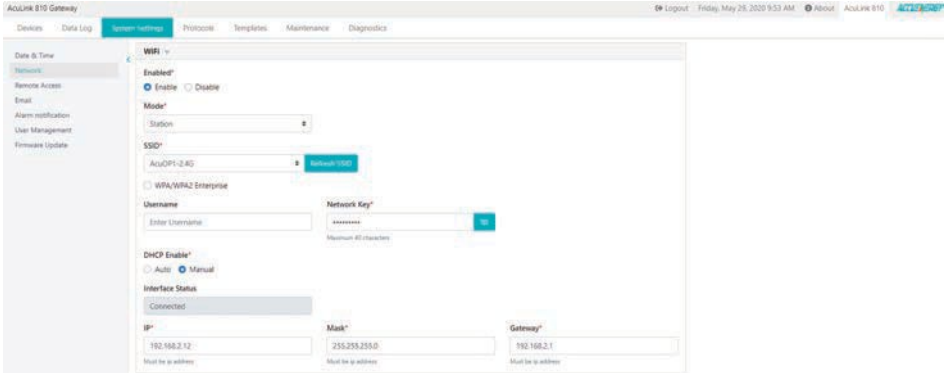

- Enterprise WiFi - The AcuLink 810 supports Enterprise WiFi, where users can connect using an enterprise level WiFi network which is common in many colleges/universities, hospitals, etc. When attempting to connect to an enterprise level WiFi network, select the WPA/WPA2 Enterprise check box and enter in the username and password to connect to the network.

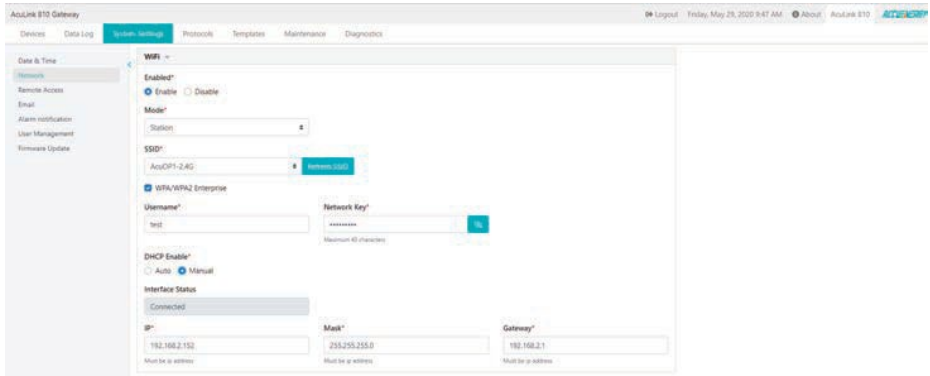

### 8.1.3 HTTP Proxy

The AcuLink 810 supports HTTP proxy configuration which allows users to post data to their servers via a proxy server.

To configure the HTTP proxy enter in the proxy url and port number.

HTTP Proxy ▾

HTTP Proxy Enable\*

Enable  Disable

HTTP Proxy Server URL\*

1.2.3.4

HTTP Proxy Server Port\*

3128

Range: 1 - 65535

Save

### 8.1.4 RSTP

The RSTP protocol allows users to create an Ethernet daisy chain using the two Ethernet ports of the AcuLink 810. The 810 can be daisy chained to a network switch/router, other AcuLink 810, and other devices supporting the RSTP protocol.

On the 810 web interface the RSTP protocol can be enabled in the network configuration page. Once enabled users will notice there is only one setting for both Ethernet ports as both ports would now be using the RSTP configured IP address instead of two unique IP addresses.

Users can configure the AcuLink IP manually or by setting the DHCP as Auto.

AcuLink 810 Gateway

Logout Tuesday, March 31, 2020 10:40 AM About AcuLink 810

Devices Data Log System Settings Protocols Templates Maintenance Diagnostics

Date & Time

Networks

Remote Access

Email

Alarm notification

User Management

Firmware Update

Network Configuration

RSTP Enable

Ethernet RSTP

DHCP Enable\*

Auto  Manual

Interface Status

Disconnected

IP\*

192.168.1.52

Mask\*

255.255.255.0

Gateway\*

192.168.1.1

Must be ip address

Must be ip address

Must be ip address

WiFi

DNS 1\*

8.8.8.8

DNS 2\*

8.8.4.4

Must be valid ip or domain

Must be valid ip or domain

HTTP Proxy

**NOTE:** When the RSTP is enabled users will not be able to configure Ethernet 1 and Ethernet 2, there is only 1 IP for the AcuLink using RSTP protocol.

## Network Topology

Users can daisy chain up to 32 devices using the RSTP protocol. This can cut down the number of network switches required in different applications and allows the use of 1 network switch/router to be used with up to 32 devices. Each device can be accessed by configuring a unique IP address or having the IP addresses assigned automatically by the network.

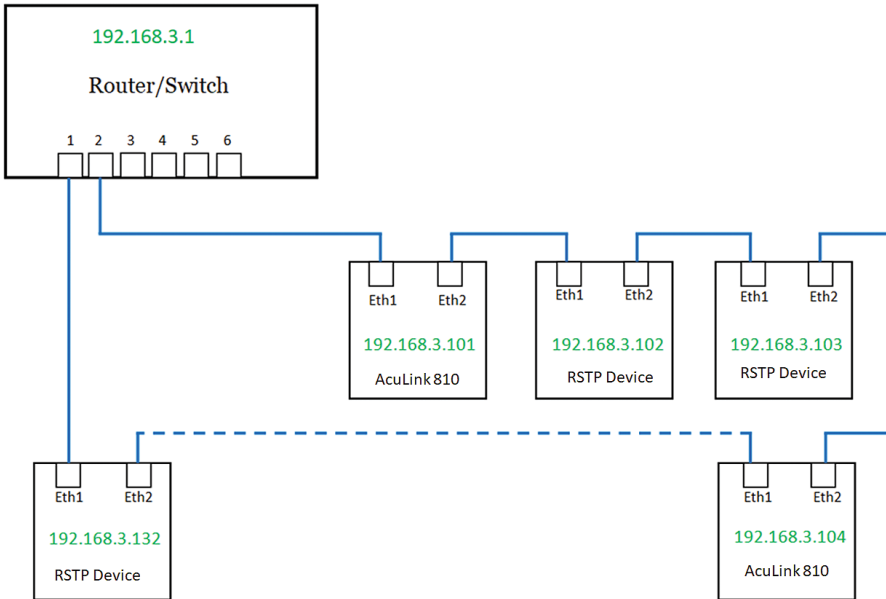

## 8.1.5 Default Routing Interface

The AcuLink 810 supports a routing default interface setting which allows users to configure which port to use for primary routing to external networks. Since there are multiple ways the user can connect such as Ethernet1/2, WiFi, RSTP, this setting will establish which one is used for the main routing. The other interfaces can be used for local routing if the users has them connected.

Users can select the default routing interface as:

- Ethernet 1
- Ethernet 2
- WiFi - only valid if WiFi is configured for station mode
- Bridge (RSTP) - only valid if RSTP is enabled

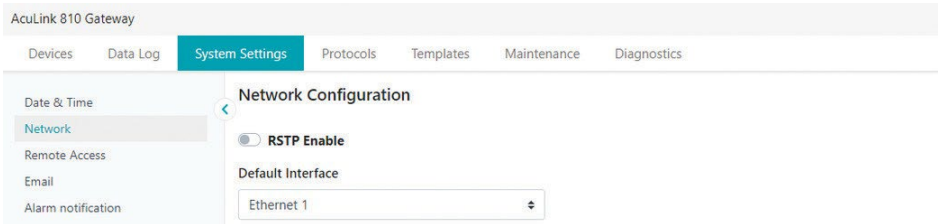

## 8.2 Whitelist

The AcuLink 810 supports the access control function, also known as the IP whitelist.

When enabled, only the selected IP addresses can access the gateway's web interface. Users can enter in an IPv4 address along with a description for the address. There is a maximum of 20 IP addresses that can be added to the IP Whitelist.

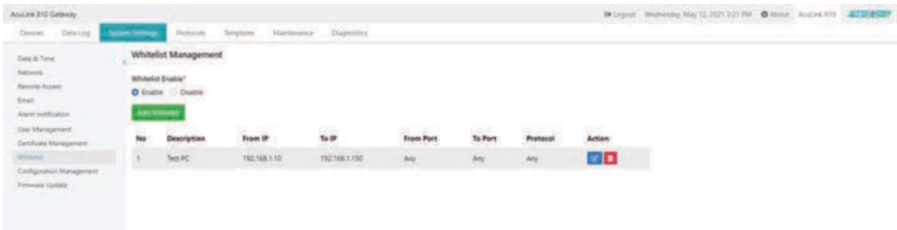

When adding the whitelist users have the option to configure a specific IP or IP range, Port, Protocol, and description.

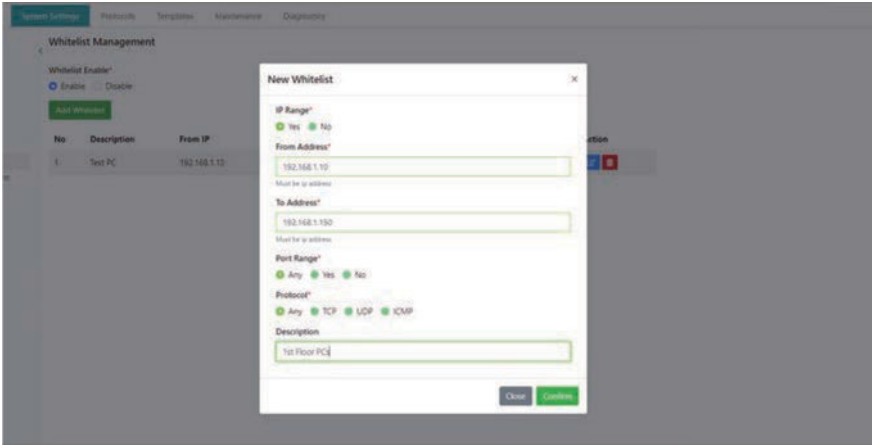

### 8.3 Time & Date

The **Date & Time** page under the **System Settings** tab is where users can configure the local time of the gateway. The AcuLink 810 supports NTP (Network Time Protocol) where it can synchronize its time to NTP servers across the network.

**NOTE:** In order to synchronize the AcuLink 810's time to the NTP time servers an internet connection is required.

If users do not want to sync the device time to an NTP server they can disable the NTP setting and configure the time and date manually.

- **Time Sync:** Users can force the time to update to the NTP on the AcuLink 810 by clicking the Sync button.
- **NTP Time Servers:** The AcuLink 810 supports can be synced with up to 3 time servers. By default the gateway uses [0.u.pool.ntp.org](http://0.u.pool.ntp.org) time server. Users can remove and add their own time servers as needed.

Examples of North American NTP servers are:

[0.us.pool.ntp.org](http://0.us.pool.ntp.org)

[1.us.pool.ntp.org](http://1.us.pool.ntp.org)

[2.us.pool.ntp.org](http://2.us.pool.ntp.org)

[3.us.pool.ntp.org](http://3.us.pool.ntp.org)

For more NTP servers based on region, visit the following site:

<http://www.pool.ntp.org/en/>

- **Time Zone:** Users can select the timezone where the gateway is installed in the drop down menu. Alternatively users can simply click on the region/country on the map displayed to select the desired timezone.

Once the time and date is configured users will notice the desired time displayed on the top right corner of the web interface.

The screenshot shows the 'Date & Time Configuration' page in the AcuLink 810 Gateway web interface. The page has a top navigation bar with 'Logout', 'Tuesday, March 10, 2020 12:25 PM', 'About', and 'AcuLink 810'. Below the navigation bar are tabs for 'Devices', 'Data Log', 'System Settings' (selected), 'Protocols', 'Templates', 'Maintenance', and 'Diagnostics'. A left sidebar lists menu items: 'Date & Time', 'Network', 'Remote Access', 'Email', 'Alarm notification', 'User Management', and 'Firmware Update'. The main content area is titled 'Date & Time Configuration' and includes the following settings:

- NTP Enable:** Radio buttons for 'Enable' (selected) and 'Disable'.
- Device Clock:** A text field showing '2020/03/10 12:25 PM' and a 'Sync' button. Below it, it says 'Last updated at 2019-10-28 09:00:00'.
- NTP Server 1:** A text field containing '0.us.pool.ntp.org' with a note 'Maximum 40 characters' below it.
- NTP Server 2:** A text field with the placeholder 'Enter NTP Server 2' and a note 'Maximum 40 characters' below it.
- NTP Server 3:** A text field with the placeholder 'Enter NTP Server 3' and a note 'Maximum 40 characters' below it.
- Timezone:** A dropdown menu currently set to 'America/Toronto (EDT)'.

At the bottom of the configuration area, there are two world maps. The left map shows North and South America, and the right map shows Europe, Africa, and Asia. The 'America/Toronto' region is highlighted in blue on the left map.

## 8.4 Remote Access

The AcuLink 810 supports a remote access function that allows users to access the AcuLink 810 web interface. By accessing the interface remotely users will have full functionality as well as access to all gateway settings and device readings. This feature allows users to access the AcuLink 810 web interface through an HTTPS web server easily through a URL without any network port forwarding. Users simply register for remote access on the web server and a

## AcuLink 810 Data Acquisition Server

remote access URL is provided where they can configure settings and view meter data. This is useful as the gateway device may be installed on remote sites where the end user may be miles away from the actual device.

The remote access configuration can be found on by clicking on the **System Settings** tab and selecting **Remote Access**.

Users must first register for remote access by clicking on **Manual Register**. Once successfully registered, enable remote access and click on **Save**.

**NOTE:** In order to successfully register for remote access there must be an internet connection provided to the AcuLink 810.

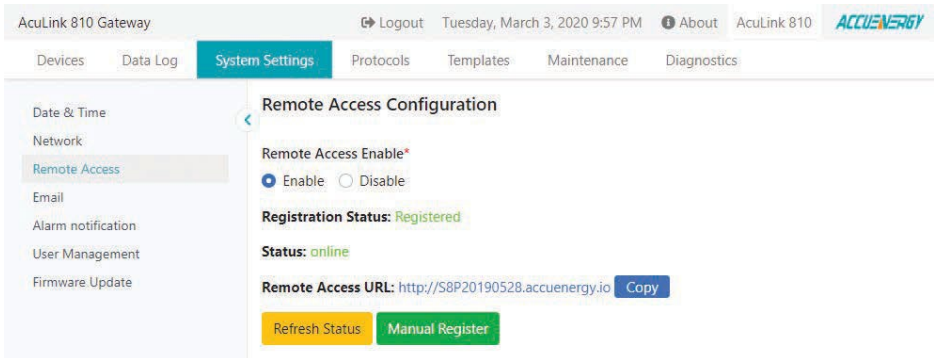

The screenshot shows the 'AcuLink 810 Gateway' interface. At the top, there is a navigation bar with 'Logout', 'Tuesday, March 3, 2020 9:57 PM', 'About', and 'AcuLink 810' with the ACCUENERGY logo. Below this is a menu with 'Devices', 'Data Log', 'System Settings' (highlighted), 'Protocols', 'Templates', 'Maintenance', and 'Diagnostics'. On the left, a sidebar lists 'Date & Time', 'Network', 'Remote Access' (highlighted), 'Email', 'Alarm notification', 'User Management', and 'Firmware Update'. The main content area is titled 'Remote Access Configuration' and includes: 'Remote Access Enable\*' with radio buttons for 'Enable' (selected) and 'Disable'; 'Registration Status: Registered' in green; 'Status: online' in green; 'Remote Access URL: http://S8P20190528.accuenergy.io' with a 'Copy' button; and two buttons at the bottom: 'Refresh Status' (yellow) and 'Manual Register' (green).

When first enabling remote access and registering the status will be displayed as offline, users may click on the **Refresh Status** button to see the status turn to online. Once the status is online the remote access user interface can be accessed by clicking on the remote access url or by using the copy button and pasting the url into a new tab on the internet browser.

The remote access login credentials are the same as if the user were to login to the interface locally. The default login credentials for the **User** access level the password is **view**, and for the **Admin** access level the password is **admin**.



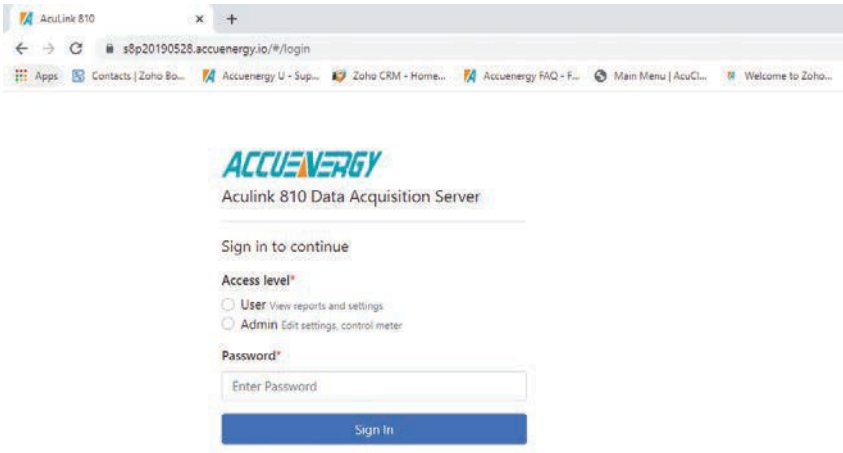

## 8.5 User Management

The AcuLink 810 supports the creation of different users for the web interface. Each user can have different roles where the role configuration determines what permission and functions users will have when logged in. To access the User configuration page click on the User Management tab.

### 8.5.1 General

Under the general tab, the maximum concurrent logins and session timeout settings can be configured. The maximum concurrent login setting allows the user to configure how many users can be logged into the web interface at the same time. If the limit is exceeded for users, the user that logged in first would be logged out of the web interface (first in first out method). The range for this setting is from 1-10, the default setting is 1.

The session timeout setting represents how long in minutes the user can access the web interface before it times out. When the session timeout limit is reached users will be logged out of the web interface and redirected back to the login page. The session timeout is set to 10 minutes as default, and can be set from 0-60 where 0 means the web interface will never timeout.

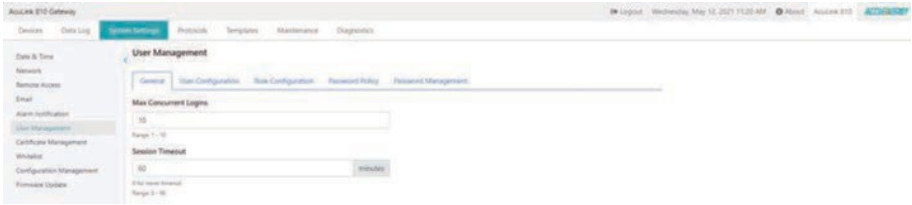

### 8.5.2 User Configuration

The user configuration table provides information regarding the access level, such as the register date, expiration date and last login time. If the correct permission is available on the account, users have the option to lock an account, and also edit and delete users.

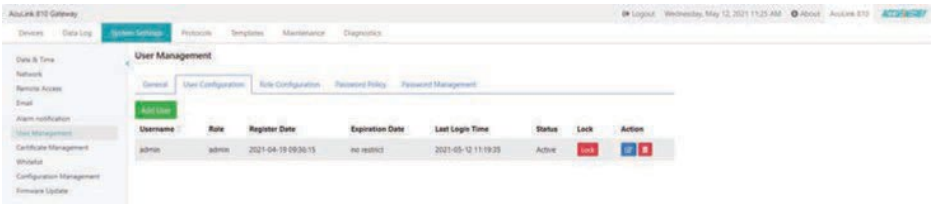

New users can be added where a user name, password, role, and option to override the password policy is available. The role determines the type of access the user will have on the user level created. Users have the option to override the password policy which is a set of rules for allowable passwords on the AcuLink 810 interface, this includes length and complexity of the password (capital letters, number, special characters, etc.).

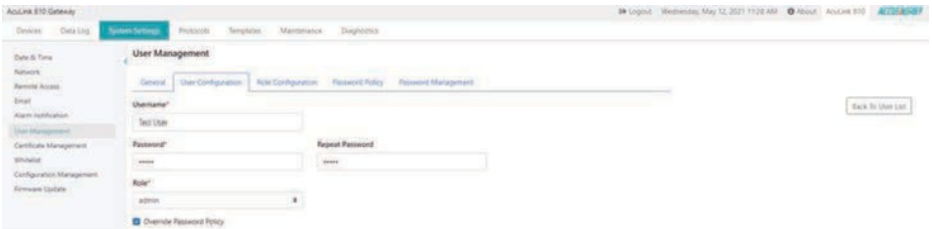

### 8.5.3 Role Configuration

The role configuration allows users to configure and create different roles for user levels. These roles determine whether the user has edit, view or no access to certain features on the web interface. By default there are two roles on the module, **Admin** and **View**. The admin role allows the user to view and configure all settings where as the view role allows users to only view meter readings.



When adding a new role, users can specify which sections of the AcuLink 810 web interface have view or edit access.

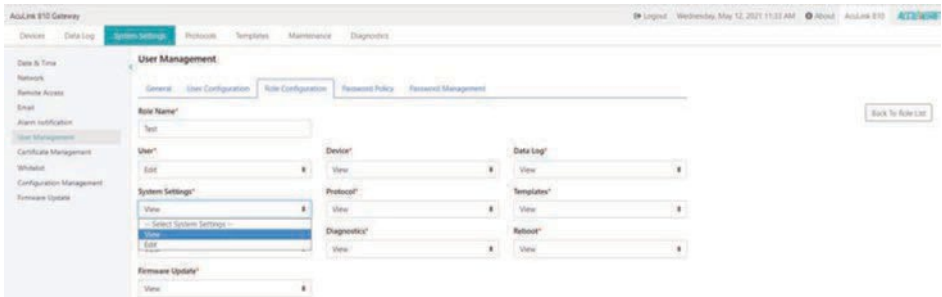

### 8.5.4 Password Policy

The password policy provides users with a method in ensuring that all passwords created follow specific criteria. The password policy lists specific details relating to the password that some users may find beneficial for security purposes. When creating a user password there is an option to override the password policy if desired.

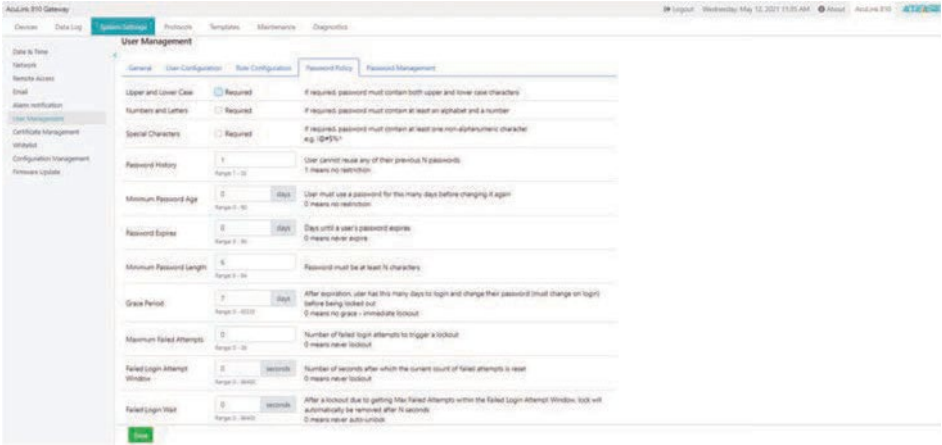

### 8.5.5 Password Management

The password management page allows users to change the password for the different user levels created.

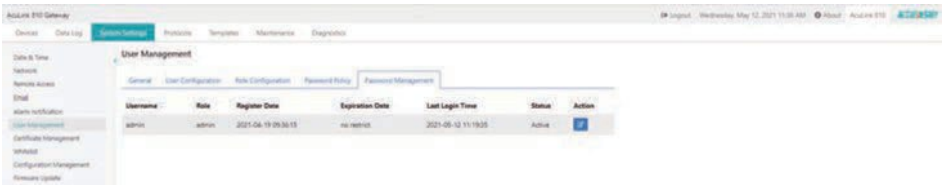

### 8.6 Certificate Management

From the AcuLink 810 web interface, there is a certificate management section that allows users to view the web page certificate details. Users can also generate a new self signed certificate, generate a certificate signed request, and import/export the certificates.

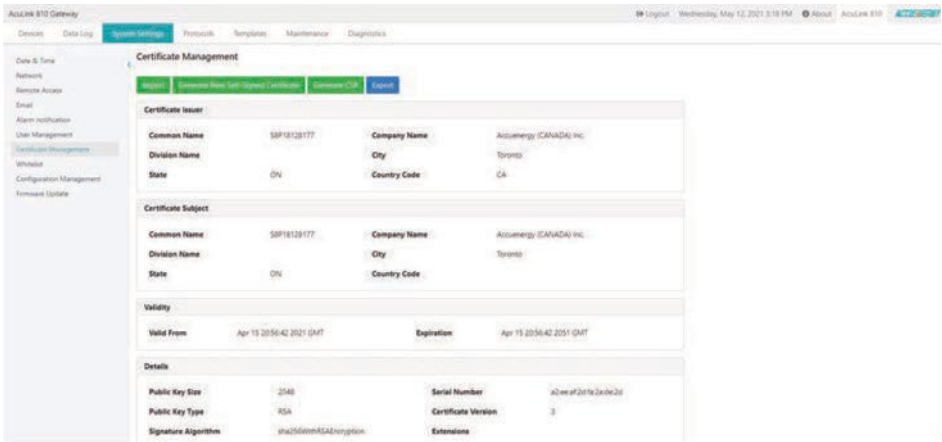

## 8.7 Configuration Management

The AcuLink 810 has a configuration management page that allows users to save all web settings with the exception of a certain settings into a configuration file. This is useful if users have more than one gateway that needs to be programmed with the same settings, and eliminates any error when trying to configure another gateway.

The following settings are saved in the configuration file:

- All Gateway settings (General, IO, Alarm, Custom Read, Waveform)
- Network settings (Only DNS1, DNS2, TCP Port, HTTP Proxy)
- All Email settings
- All Time/Date settings
- All Data Log settings
- All Post Channel settings
- All BACnet settings
- All SNMP settings
- User Management settings (user name/passwords, etc)
- Debug Information (SSH, and Debug Configuration)

The settings that are not included or effected by the Configuration Management file is:

- Most Network settings (RSTP, DHCP, IP, Submask, Gateway, HTTP Port for both Ethernet 1 and 2, All WiFi settings)
- AcuCloud
- IP Whitelist
- Remote Access



# Chapter 9: Protocols

## 9.1 Modbus

This chapter outlines to users how to add devices from the AcuLink 810 web interface using the Modbus protocol.

The AcuLink 810 supports both Modbus RTU and Modbus TCP protocols.

### 9.1.1 RS485 Devices

The AcuLink 810 gateway supports RS485 serial communication. Users can set up an RS485 connection to the AcuLink with any Accuenergy or third party device. If connecting multiple devices or 'daisy-chaining' the devices together, ensure that a unique device address (Modbus Slave ID) is configured for each RS485 device. The AcuLink 810 can support up to 32 external RS485 devices.

**NOTE:** A termination resistor at the end of the RS485 network is optional when daisy-chaining multiple devices. If using a resistor a termination value of 150 ohms can be used.

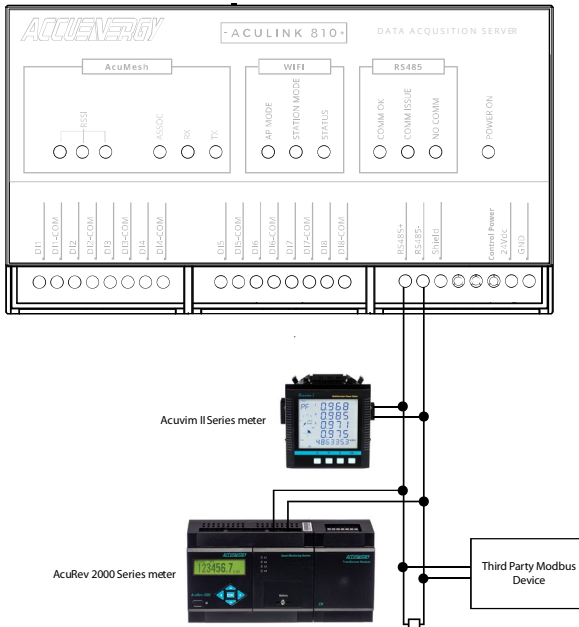

## 9.1.2 USB Devices

The AcuLink 810 has a USB port that allows for an additional 32 Modbus RTU devices. Users can connect the additional using an RS485 to USB converter cable.

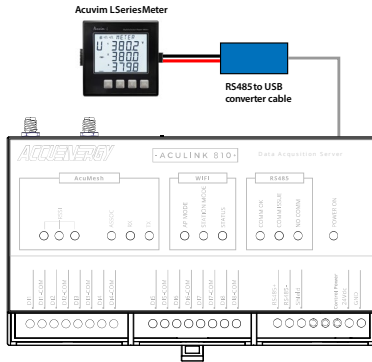

## 9.1.3 Adding Modbus RTU Device

By default the RS485 and USB port of the AcuLink 810 and configured for the Modbus protocol. Users can configure the protocol of the RS485 and USB ports from the **Interface Assignment** page under the **Protocols** tab.

**NOTE:** Users will not be able to change the Interface assignment of the USB or RS485 port if there is a device added on the 810 with one of the selected protocols. The device must be deleted from the AcuLink in order to change the protocol of the ports.

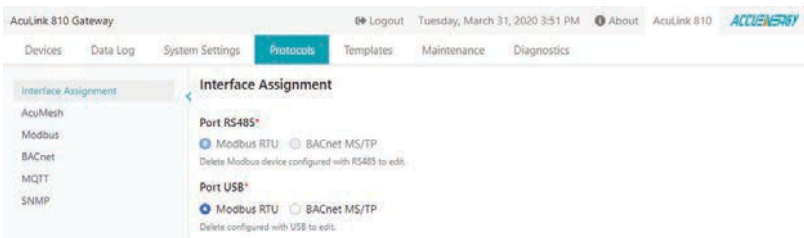

With the Modbus RTU protocol selected, to add a Modbus RTU device via RS485 or USB navigate to the **Modbus Devices** page under the **Devices** tab. Click on **Add Device**, the following fields will need to be configured:



**Device Name:** Enter the device name.

**Serial Number:** Enter the serial number of the device being added, the serial number must be unique consisting of only letters and numbers.

**Template:** User will need to select the Modbus template for the device. For information regarding the Modbus Device template see section 7.3 of this User's Manual.

**Protocol:** Select RTU as the protocol.

**Port:** Select either RS485 or USB.

**Modbus ID:** Enter the device address (Modbus Slave ID) of the device, the range is from 1-247.

**Baud Rate:** Select the baud rate of the device, the range is from 9600-115200.

**Data Bit:** Select the number of data bits, either 7 or 8.

**Parity:** Select the parity of the device from the drop-down list.

**Stop Bit:** Select the number of Stop Bits.

**Request Timeout:** Select a timeout period for the AcuLink 810 to wait for a response from the device, the range is 1-60 seconds, default for Modbus RTU is 0.5.

**NOTE:** Users cannot add device with the same device address (Modbus Slave ID). The device address must be unique for each device in the RS485 network.

Click **Save** once all settings are entered correctly.

The screenshot shows a web-based configuration interface for adding a Modbus device. The form is titled 'Add Modbus Device' and contains the following fields and options:

- Device Name:** A text input field with a green border.
- Serial Number:** A text input field with a green border.
- Protocol:** A dropdown menu with 'RTU' selected (indicated by a blue radio button).
- Port:** A dropdown menu with 'RS485' selected (indicated by a blue radio button).
- Baud Rate:** A dropdown menu with '19200' selected.
- Data Bit:** A dropdown menu with '8' selected.
- Parity:** A dropdown menu with 'None' selected.
- Stop Bit:** A dropdown menu with '2' selected.
- Request Timeout:** A text input field with '0.5' entered and a 'seconds' unit label.

At the bottom of the form, there are two buttons: a green 'Save' button and a grey 'Cancel' button.

## AcuLink 810 Data Acquisition Server

After the device is added, it can be found in the **Modbus Devices** pages. A device that is successfully connected and communicating with the gateway will have display a green **ON** status under the status column. A device that is offline will display a red **OFF** warning symbol under the status menu.

**NOTE:** After adding a new device to the gateway it may take up to 3-4 minutes for the status to show 'ON'. If after 3-4 minutes the device is showing an 'OFF' status, double-check the configuration settings to ensure everything is set correctly.

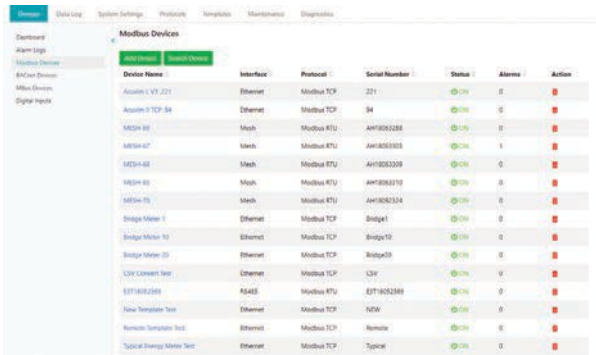

Device Name	Interface	Protocol	Serial Number	Status	Alarms	Action
AcuLink V1_V1_221	Ethernet	Modbus TCP	221	ON	0	
AcuLink V1 TCP_84	Ethernet	Modbus TCP	84	ON	0	
M254-89	Modbus	Modbus RTU	AH18030288	ON	0	
M254-82	Modbus	Modbus RTU	AH18030303	ON	1	
M254-88	Modbus	Modbus RTU	AH18030309	ON	0	
M254-85	Modbus	Modbus RTU	AH18030310	ON	0	
M254-79	Modbus	Modbus RTU	AH18030314	ON	0	
Bridge Meter 1	Ethernet	Modbus TCP	Bridge1	ON	0	
Bridge Meter 10	Ethernet	Modbus TCP	Bridge10	ON	0	
Bridge Meter 20	Ethernet	Modbus TCP	Bridge20	ON	0	
LDV Control Test	Ethernet	Modbus TCP	LDV	ON	0	
E3T16092569	RS485	Modbus RTU	E3T16092569	ON	0	
New Template Test	Ethernet	Modbus TCP	NEW	ON	0	
Remote Template Test	Ethernet	Modbus TCP	Remote	ON	0	
Typical Energy Meter Test	Ethernet	Modbus TCP	Typical	ON	0	

If users need to change the configuration of an added device, they can simply click on the device and then select the **Configuration**. From this page users can re-configure the device name, port type, baud rate, parity, etc.

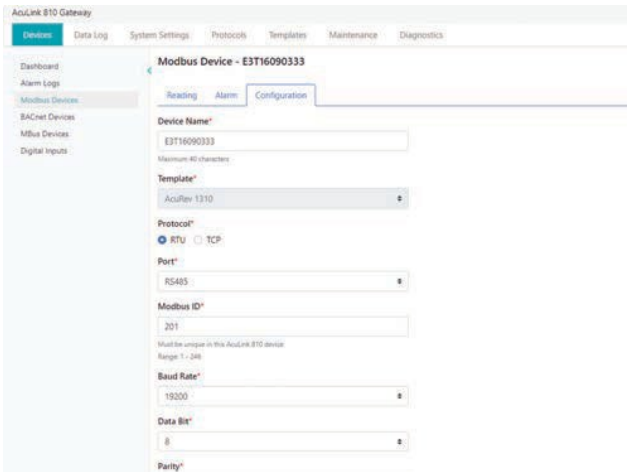

AcuLink 810 Gateway

Devices | Data Log | System Settings | Protocols | Templates | Maintenance | Diagnostics

Modbus Device - E3T16090333

Reading | Alarm | Configuration

Device Name\*  
E3T16090333  
Maximum: 40 characters

Template\*  
AcuRev 1310

Protocol\*  
 RTU  TCP

Port\*  
RS485

Modbus ID\*  
201  
Must be unique in this AcuLink 810 device.  
Range: 1 - 248

Baud Rate\*  
19200

Data Bit\*  
8

Parity\*

### 9.1.4 TCP Devices

The AcuLink 810 can support up to 100 Modbus TCP devices where the devices will need to be on the same network as the gateway.

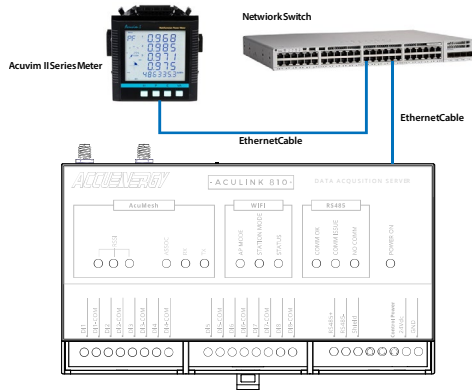

### 9.1.5 Adding Modbus TCP Device

To add a Modbus TCP device click on **Add Device** from the **Modbus Devices** page under the **Devices** tab. The following fields will need to be configured:

**Device Name:** Enter the device name of the TCP device.

**Serial Number:** Enter the serial number of the device, the serial number must be unique and consisting of only letters and numbers.

**Template:** Select the Modbus template for the TCP device, for more information regarding Modbus templates see sections 7.3 of this User's Manual.

**Protocol:** Select TCP as the protocol.

**IP Address:** Enter the IP address of the device.

**Port:** Enter the Modbus port of the device.

**Modbus ID:** Enter the Modbus address of the device.

**Request Timeout:** Enter the timeout setting, default for TCP is 3 seconds

Click **Save** once all settings are entered correctly.

**Devices** | Data Log | System Settings | Protocols | Templates | Maintenance | Diagnostics

Dashboard  
Alarm Logs  
**Modbus Devices**  
BACnet Devices  
MBus Devices  
Digital Inputs

### Add Modbus Device

**Device Name\***  
Test  
Maximum: 40 characters

**Serial Number\***  
AH11223344  
Must be unique in this AcuLink 810 device  
Maximum: 20 characters

**Template\***  
Acuvim II

**Protocol\***  
 RTU  TCP

**IP Address\***  
192.168.1.94  
Must be ip address

**Port\***  
502  
Range: 1 - 65535

**Modbus ID\***  
1  
Range: 1 - 246

**Request Timeout\***  
3 seconds  
Range: 0.1 - 5

**Save** **Cancel**

After the device is added, it can be found in the **Modbus Devices** pages. A device that is successfully connected and communicating with the gateway will have display a green **ON** status under the status column. Whiles a device that is offline will display a red **OFF** warning symbol under the status menu.

**NOTE:** After adding a new device to the gateway it may take up to 3-4 minutes for the status to show 'ON'. If after 3-4 minutes the device is showing an 'OFF' status, double-check the configuration settings to ensure everything is set correctly.

Device Name	Interface	Protocol	Serial Number	Status	Alarms	Action
Acuvim I V3_221	Ethernet	Modbus TCP	221	ON	0	
Acuvim II TCP_94	Ethernet	Modbus TCP	94	ON	0	
MESH-69	Mesh	Modbus RTU	AH18063288	ON	0	
MESH-67	Mesh	Modbus RTU	AH18063303	ON	1	
MESH-68	Mesh	Modbus RTU	AH18063309	ON	0	
MESH-65	Mesh	Modbus RTU	AH18063310	ON	0	
MESH-70	Mesh	Modbus RTU	AH18092324	ON	0	
Bridge Meter 1	Ethernet	Modbus TCP	Bridge1	ON	0	
Bridge Meter 10	Ethernet	Modbus TCP	Bridge10	ON	0	
Bridge Meter 20	Ethernet	Modbus TCP	Bridge20	ON	0	
CSV Convert Test	Ethernet	Modbus TCP	CSV	ON	0	
E3T18052569	RS485	Modbus RTU	E3T18052569	ON	0	
New Template Test	Ethernet	Modbus TCP	NEW	ON	0	
Remote Template Test	Ethernet	Modbus TCP	Remote	ON	0	
Typical Energy Meter Test	Ethernet	Modbus TCP	Typical	ON	0	

If users need to change the configuration of an added device, they can simply click on the device and then select the **Configuration**. From this page users can re-configure the device name, port type, IP address, Modbus ID, etc.

AcuLink 810 Gateway

Devices | Data Log | System Settings | Protocols | Templates | Maintenance | Diagnostics

Dashboard  
Alarm Logs  
Modbus Devices  
BACnet Devices  
Mbus Devices  
Digital Inputs

### Modbus Device - 94

Reading | Alarm | Configuration

**Device Name\***  
Acuvim II TCP\_94  
Maximum 40 characters

**Template\***  
Acuvim II\_JO1

**Protocol\***  
 RTU  TCP

**IP Address\***  
192.168.1.94  
Must be ip address

**Port\***  
502  
Range: 1 - 65535

**Modbus ID\***  
3  
Range: 1 - 246

**Request Timeout\***  
3.0 seconds  
Range: 0.1 - 5

### 9.1.6 Modbus Gateway Function

The AcuLink 810 supports a Modbus Gateway Function, where users can add a Modbus RTU device and use it as a gateway. Users must choose the device template as **Modbus Gateway Function Only**.

The Modbus Gateway Function allows users to forward a Modbus TCP request to the corresponding meter. A **Modbus Gateway Function Only** device allows the user to read/write to the Modbus registers of this device via Modbus Gateway function. Unlike other Modbus devices, the AcuLink 810 does not periodically collect data for Modbus Gateway devices.

#### Adding Modbus Gateway Device

To add a Modbus Gateway device, select add device. Under the **Template** setting select **Modbus Gateway Function Only**. Select **RTU** as the protocol and enter in the communication settings for that RTU device (baud rate, parity, Modbus ID, etc).

Click on **Save** once all information is entered in correctly.

**NOTE:** Only Modbus RTU devices can be used as a Modbus Gateway Function on the AcuLink 810.

The screenshot displays the 'AcuLink 810 Gateway' web interface. The top navigation bar includes 'Devices', 'Data Log', 'System Settings', 'Protocols', 'Templates', 'Maintenance', and 'Diagnostics'. The left sidebar shows a menu with 'Dashboard', 'Alarm Logs', 'Modbus Devices' (highlighted), 'BACnet Devices', 'Mbus Devices', and 'Digital Inputs'. The main content area is titled 'Add Modbus Device' and contains the following fields:

- Device Name\***: Text input field containing 'Gateway Device'. Below it, a note states 'Maximum 40 characters'.
- Serial Number\***: Text input field containing 'AH1249234'. Below it, a note states 'Must be unique in this AcuLink 810 device' and 'Maximum 20 characters'.
- Template\***: A dropdown menu with 'Modbus Gateway Function Only' selected.
- Protocol\***: Radio buttons for 'RTU' (selected) and 'TCP'.
- Port\***: A dropdown menu with 'RS485' selected.
- Modbus ID\***: Text input field containing '23'. Below it, a note states 'Must be unique in this AcuLink 810 device' and 'Range: 1 - 246'.
- Baud Rate\***: A dropdown menu with '38400' selected.
- Data Bit\***: A dropdown menu (partially visible).

At the bottom of the form are two buttons: a green 'Save' button and a grey 'Cancel' button.

## 9.2 AcuMesh

Certain models of the AcuLink 810 supports AcuMesh which allows for a wireless RS485 network. The gateway has a built in AcuMesh into its hardware which allows the 810 to connect wirelessly via RS485 to gather information from both Accuenergy and third party Modbus devices using AcuMesh transceivers/modules.

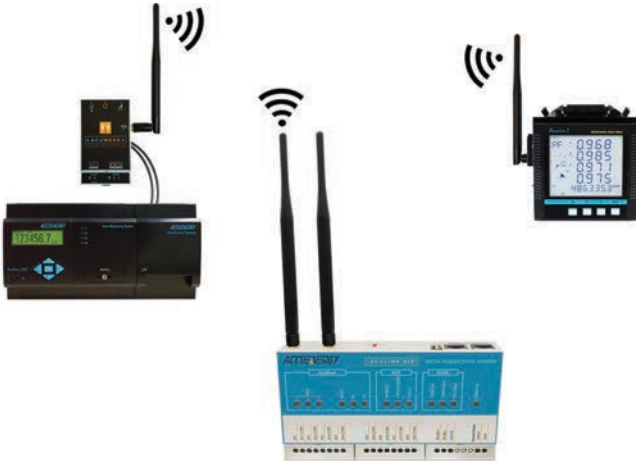

There are two AcuMesh models for the AcuLink 810:

- AcuLink-868 (868 MHz) is used mostly in Europe, Middle East, Africa, and certain parts of Asia.
- The AcuLink-900 (900 MHz) is mainly used in North and South America, Oceania, and also certain parts of Asia.

**NOTE:** The AcuLink 810-X model does not support AcuMesh.

To configure the AcuMesh settings on the AcuLink 810 click on the **Protocols** tab and select **AcuMesh**.

### 9.2.1 Local Configuration

In order for the AcuLink to add other AcuMesh devices, the local AcuMesh settings must be configured first. The local configuration page refers to the AcuMesh unit built into the AcuLink 810.

The following can be configured on the local configuration page:

**Node Name:** Users can configure the name of the AcuMesh node in this settings, the maximum range is up to 14 characters.

**Local MAC Address:** The built in AcuMesh transceiver will have a local MAC address that is used to identify the unit, this is non configurable.

**Network Hop:** By default the network hop is set to 4 and represents the amount of times the AcuMesh will scan the mesh network for devices. The range for this setting is from 1-7.

**Network ID:** The network ID is a hex number that is used as an AcuMesh Network Identifier. By default the network ID is 7FFF, and the range is 0-7FFF (Hex).

**NOTE:** Only transceivers with the same matching network ID can discover and communicate with each other.

**Encryption Enable:** Users have the option to put a password on the AcuMesh device. All radio AcuMesh devices would need to have the same password in order to communicate in the AcuMesh network.

**Encryption Key:** The encryption key is a hex number where the maximum number of characters is 32.

AcuLink 810 Gateway

Logout Tuesday, March 31, 2020 3:00 PM About AcuLink 810 ACUMESH

Devices Data Log System Settings Protocols Templates Maintenance Diagnostics

Interface Assignment

AcuMesh Modbus BACnet MQTT SNMP

AcuMesh Configuration

Local Configuration Scan & Remote Configuration Diagnostics

Node Name\*  
AcuLink\_810  
Maximum: 14 characters

Local MAC Address  
0013a2004103ad9d

Network ID\*  
7FFF  
Range: 0-7FFF

Encryption Enable\*  
 Enable  Disable

Encryption Key  
Enter Encryption Key

Network Hop\*  
4  
Range: 1-7



## 9.2.2 Scan & Remote Configuration

Once the Local Configuration has been set, users can then scan for remote radio AcuMesh transceivers. Click on the **Scan & Remote Configuration** tab on the AcuMesh configuration page, users will be directed to the following page.

The Local configuration will appear under the Node Scan section. This will show the Network ID that will be scanned, the Encryption, and the Channel Mask that is being used.

The network Hops configuration is the number of times the mesh network will be scanned, the range is from 1-7 network hops.

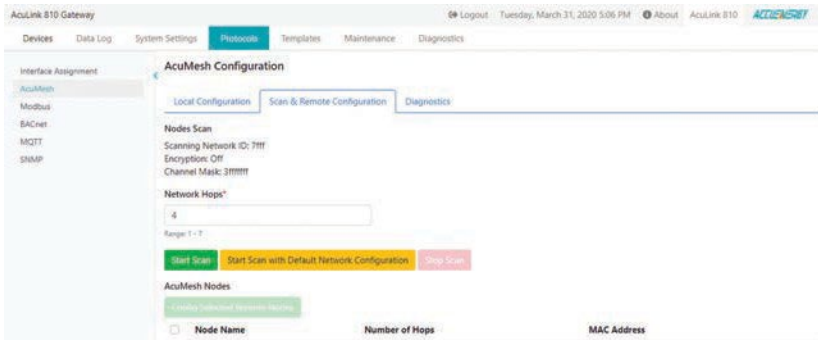

Click on **Start Scan** to search for remote AcuMesh transceivers.

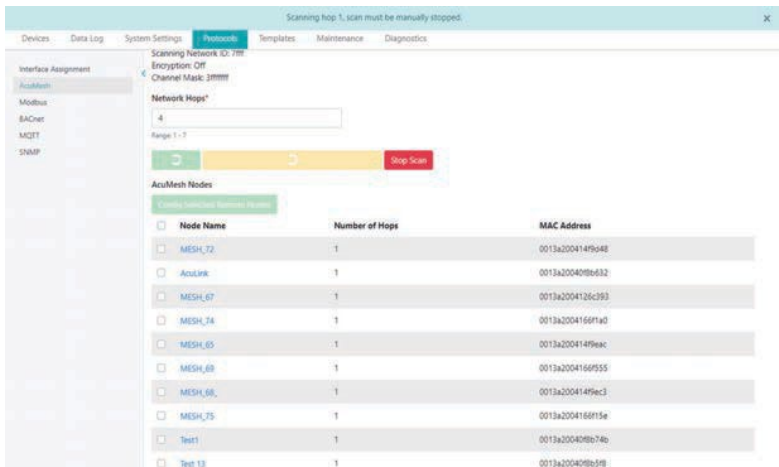

All devices found during the scan will have the AcuMesh Node name, the number of network hops that the Mesh device was discovered in, and the MAC address displayed on the interface.

Users can simply click on the check box next to the Node name to configure the radio Mesh transceiver, or if users wish to configure multiple Mesh devices they can select the check box next to the Node name and then click on the **Config Selected Remote Nodes** button.

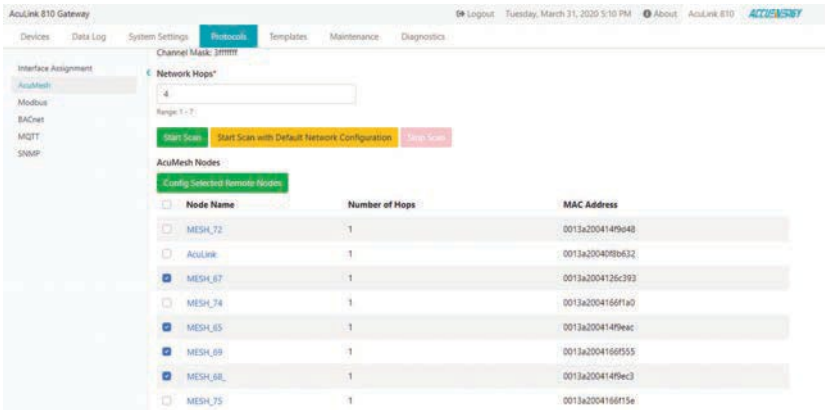

The following settings on the remote AcuMesh transceivers can be configured:

**Network ID:** The network ID is a hex number that is used as an AcuMesh Network Identifier. By default the network ID is 7FFF, and the range is 0-7FFF (Hex).

**NOTE:** Only transceivers with the same matching network ID can discover and communicate with each other.

**Destination MAC Address:** The MAC Address of the remote transceivers.

**Encryption Enable:** Users have the option to put a password on the AcuMesh device. All radio AcuMesh would need to have the same password in order to communicate in the AcuMesh network.

**Encryption Key:** The encryption key is a hex number where the max amount of characters is 32.

Advanced Options:

**Baud Rate:** Select the baud rate of the device, range is from 9600-115200.

**Parity:** Select the parity of the device from the drop down list.

**Stop Bit:** Select the number of Stop Bits.

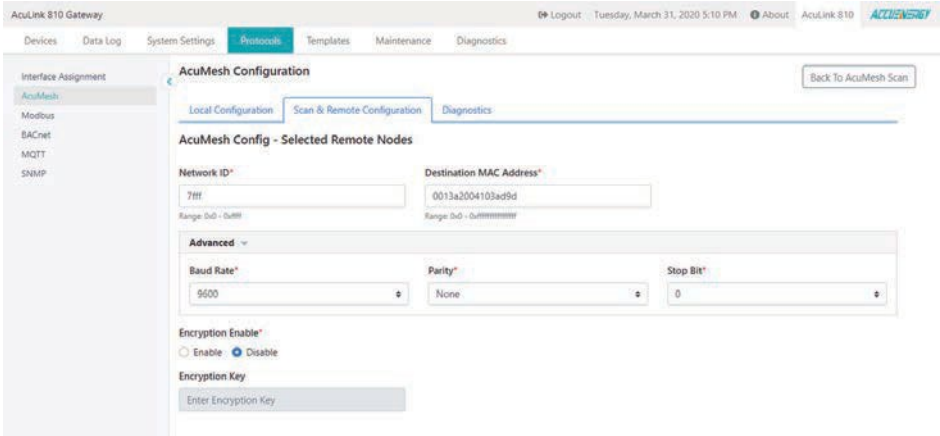

## Managed Nodes

Users can select which module to manage from the list of discovered transceivers. The managed nodes will allow users to only see particular managed transceivers when adding the AcuMesh devices to the AcuLink 810. For example if there is a network of 50 AcuMesh devices, but only 10 AcuMesh devices are required to be added to the AcuLink 810, the user can add these 10 to the managed list. Once added to the managed list only these 10 transceivers will be available when adding an AcuMesh device rather than all discovered transceivers.

Users can click on the green icon under the Action column to add a device to the managed list. Alternatively the check boxes can be used to select multiple transceivers and the **Manage Selected Nodes** button can be used to add multiple transceivers to the managed nodes list.

AcuMesh Nodes

Config Selected Nodes
  Reset Selected Nodes
  Manage Selected Nodes

<input type="checkbox"/>	Managed	Node Name	Number of Hops	MAC Address	Action
<input type="checkbox"/>	No	MESH_69	1	0013a2004166f555	<input type="checkbox"/> <input type="checkbox"/> <input checked="" type="checkbox"/>
<input checked="" type="checkbox"/>	No	MESH_68	1	0013a200414f9ec3	<input type="checkbox"/> <input type="checkbox"/> <input checked="" type="checkbox"/>
<input checked="" type="checkbox"/>	No	MESH_67	1	0013a2004126c393	<input type="checkbox"/> <input type="checkbox"/> <input checked="" type="checkbox"/>
<input type="checkbox"/>	No	MESH_65	1	0013a200414f9eac	<input type="checkbox"/> <input type="checkbox"/> <input checked="" type="checkbox"/>

## Reset Nodes

Users can perform a soft reboot of the discovered AcuMesh transceivers. This can be very useful as sometimes communication is dropped due to timeouts and requires a reboot to initialize and restore the communication. The yellow button under the Action column will allow users to reset the AcuMesh nodes. If multiple nodes require a reset the check boxes can be used to select multiple transceivers and the **Reset Selected Nodes** button can be used to reset all selected nodes.

<input type="checkbox"/>	Managed	Node Name	Number of Hops	MAC Address	Action
<input type="checkbox"/>	No	MESH_69	1	0013a2004166f555	
<input checked="" type="checkbox"/>	No	MESH_68	1	0013a200414f9ec3	
<input checked="" type="checkbox"/>	No	MESH_67	1	0013a2004126c393	
<input type="checkbox"/>	No	MESH_65	1	0013a200414f9eac	

### 9.2.3 AcuMesh Diagnostics

The AcuMesh diagnostics page allows the user to troubleshoot the AcuMesh connection from the AcuLink 810 to the remote AcuMesh transceivers. The test sends packets at a certain interval and tests whether the AcuLink 810 gets a response from the slave AcuMesh transceivers.

**Transmission Interval:** Is the sending interval of the packet, the range is 1-100 seconds.

**Number of Packets:** Is the number of packets sent in each test query.

**Remote AcuMesh Node Selection:** Users can choose which AcuMesh transceiver they want to test from the drop down selection.

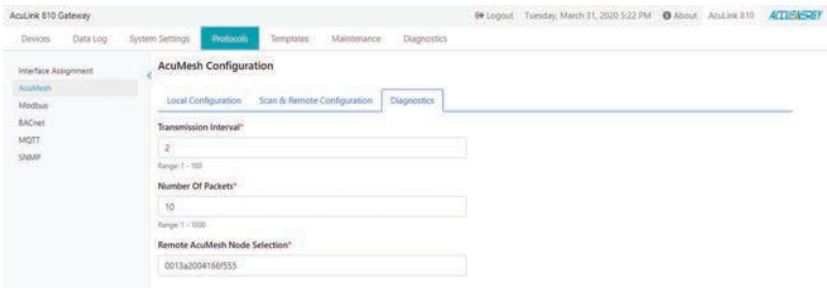

The test result will be displayed showing the success rate and average delay of the packets sent.

The screenshot shows the 'AcuMesh Configuration' page in the 'Diagnostics' tab. The 'Test Result' section displays the following data:

Test Result
Packets Sent
10
Packets Received
10
Packets Lost
0
Average Delay
0.152 s
Success Rate
100%

## 9.2.4 Adding AcuMesh Device

To add an AcuMesh device, select **Add Device** from the **Modbus Devices** page. The following fields need to be configured:

**Device Name:** Enter a device name.

**Serial Number:** Enter the serial number of the device, the serial number must be unique and consisting of only letters and numbers.

**Template:** Select the correct device model.

**Protocol:** Select RTU as the protocol.

**Port:** Select AcuMesh as the port type.

**Modbus ID:** Enter in the Modbus ID that corresponds to the Modbus device.

**AcuMesh MAC Address:** Select the AcuMesh MAC address of the remote mesh transceiver of the Modbus device. Users can click on Go to AcuMesh Scan & Configuration page to discover remote Mesh transceivers.

**Request Timeout:** The default timeout setting for an AcuMesh device is 10 seconds.

The screenshot shows the 'Add Modbus Device' configuration page in the AcuLink 810 Gateway. The page has a top navigation bar with 'Devices' selected, and a left sidebar with 'Modbus Devices' highlighted. The main form contains the following fields:

- Device Name\***: Text input with 'MESH DEVICE'. Note: Maximum 40 characters.
- Serial Number\***: Text input with 'MESH'. Note: Must be unique in this AcuLink 810 device. Maximum 20 characters.
- Template\***: Dropdown menu with 'Acuvim II' selected.
- Protocol\***: Radio buttons for 'RTU' (selected) and 'TCP'.
- Port\***: Dropdown menu with 'AcuMesh' selected.
- Modbus ID\***: Text input with '12'. Note: Must be unique in this AcuLink 810 device. Range: 1 - 246.
- AcuMesh MAC Address\***: Dropdown menu with '0013a20040f8b74b - Test1' selected. Below it is a link: 'Go To AcuMesh Scan & Configuration Page'.
- Request Timeout\***: Text input with '10' and a 'seconds' label. Note: Range: 2 - 60.

At the bottom of the form are 'Save' and 'Cancel' buttons.

After the device is added, it can be found in the **Modbus Devices** pages. A device that is successfully connected and communicating with the gateway will have display a green **ON** status under the status column. A device that is offline will display a red **OFF** warning symbol under the status menu.

**NOTE:** After adding a new device to the gateway it may take up to 3-4 minutes for the status to show 'ON'. If after 3-4 minutes the device is showing an 'OFF' status, double-check the configuration settings to ensure everything is set correctly.

Device Name	Interface	Protocol	Serial Number	Status	Alarms	Action
AcuLink 1 V3_221	Ethernet	Modbus TCP	221	ON	0	
AcuLink 1 TCP_34	Ethernet	Modbus TCP	34	ON	0	
MESH-69	Mesh	Modbus RTU	AH18063288	ON	0	
MESH-67	Mesh	Modbus RTU	AH18063233	ON	1	
MESH-68	Mesh	Modbus RTU	AH18063309	ON	0	
MESH-65	Mesh	Modbus RTU	AH18063310	ON	0	
MESH-70	Mesh	Modbus RTU	AH18063234	ON	0	
Bridge Meter 1	Ethernet	Modbus TCP	Bridge1	ON	0	
Bridge Meter 10	Ethernet	Modbus TCP	Bridge10	ON	0	
Bridge Meter 20	Ethernet	Modbus TCP	Bridge20	ON	0	
CSV Converter Test	Ethernet	Modbus TCP	CSV	ON	0	
E3718052569	RS485	Modbus RTU	E3718052569	ON	0	
New Template Test	Ethernet	Modbus TCP	NEW	ON	0	
Remote Template Test	Ethernet	Modbus TCP	Remote	ON	0	
Typical Energy Meter Test	Ethernet	Modbus TCP	Typical	ON	0	

If users need to change the configuration of an added device, they can simply click on the device and then select the **Configuration**. From this page users can re-configure the device name, port type, AcuMesh MAC addresses, Modbus ID, etc.

AcuLink 810 Gateway

Devices | Data Log | System Settings | Protocols | Templates | Maintenance | Diagnostics

Dashboard  
Alarms Logs  
Modbus Devices  
BACnet Devices  
MBus Devices  
Digital Inputs

### Modbus Device - AH18063288

Reading | Alarm | **Configuration**

**Device Name\***  
  
Maximum 40 characters

**Template\***

**Protocol\***  
 RTU  TCP

**Port\***

**Modbus ID\***  
  
Must be unique in this AcuLink 810 device  
 Range: 1 - 249

**AcuMesh MAC Address\***

[Go To AcuMesh Scan & Configuration Page](#)

**Request Timeout\***  
 seconds  
Range: 2 - 60

### 9.2.5 Search Modbus Device

There is a search device function in the AcuLink 810 gateway that allows the user to search for all Modbus devices. The search criteria is based on the template model, Modbus slave ID, baud rate, parity and port. The search function can be useful for adding several devices in a large RS485/USB daisy chain as well as a large Mesh network.

To access the search function click on **Search Device** on the **Modbus Device** page.

**NOTE:** 'Search Device' only supports the devices connected via Modbus RTU protocol.

The following search criteria will need to be specified:

**Template:** Select the Modbus template for the device.

**Port:** Select the port to scan for the Modbus search, users can select RS485, USB, and AcuMesh.

**Modbus ID Start:** Specify the starting slave address for the search.

**Modbus ID End:** Specify the ending slave address for the search.

**Baud Rate:** Select the baud rate(s) for the Modbus device search. Users can select multiple baud rates in the search.

**Data Bit:** Select the data bit, this can be set as 7 or 8.

**Stop Bit:** Select the number of stop bits, can be set as 0 or 1.

**Parity:** Select the parity for the Modbus search. Users can select multiple parity in the search.

**Request Timeout:** Select the request timeout, for RS485 and USB the default timeout is 0.5 seconds, for AcuMesh the timeout is 10 seconds.

Click on **Scan** once the search credentials are configured.

**NOTE:** Depending on the range of Modbus IDs, baud rate and parity selected the search may take several minutes to complete.



AcuLink 810 Gateway

Devices | Data Log | System Settings | Protocols | Templates | Maintenance | Diagnostics

Dashboard  
Alarm Logs  
Modbus Devices  
BACnet Devices  
Mbus Devices  
Digital Inputs

### Scan Modbus Device

Template\*  
AcuLink II

Port\*  
RS485

Modbus ID Start\*  
1  
Range: 1 - 246

Modbus ID End\*  
246  
Range: 1 - 246

Baud Rate\*  
 9600  19200  38400  57600  115200

Data Bit\*  
8

Parity\*  
 None  Odd  Even

Stop Bit\*  
1

Request Timeout\*  
0.5 seconds  
Range: 0.1 - 5

Scan Cancel

When the scan is complete all devices found will be displayed. Users have the option to individually add each found device and can also add all devices found by clicking on the add all button.

If a device is found that is already added to the AcuLink 810 it will be displayed as **Added** in the search.

If a device is found with the same Modbus ID as a device that is already added on the AcuLink 810 it will be displayed as **Conflict** in the search.

The search results show the device serial number and Modbus slave ID associated with the device. If the search is done on a AcuMesh network the AcuMesh MAC address is also displayed in the search.

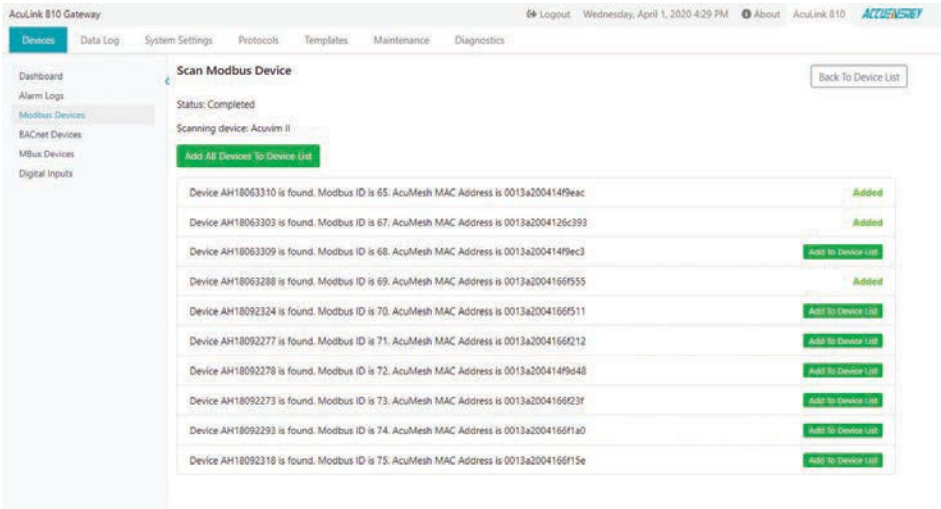

### 9.3 Modbus Polling

The AcuLink 810 supports Modbus polling for the Digital Input registers. The user can select **Protocols**, then the subheading **Modbus** in order to access the *Modbus Configuration* page.

**Modbus TCP Port:** The default is 502, the range is 2000-5999. This is also the port used for Modbus Gateway Function devices.

**Modbus ID:** The Modbus ID for the AcuLink 810 is 247, this cannot be changed.

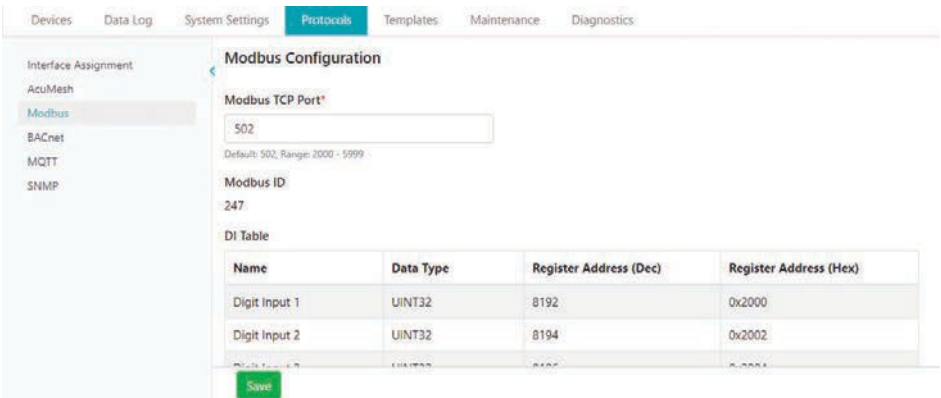

The DI Modbus Registry Map is listed below:

Name	Data Type	Register Address (Dec)	Register Address (Hex)
Digital Input 1	UINT32	8192	0x2000
Digital Input 2	UINT32	8194	0x2002
Digital Input 3	UINT32	8196	0x2004
Digital Input 4	UINT32	8198	0x2006
Digital Input 5	UINT32	8200	0x2008
Digital Input 6	UINT32	8202	0x200A
Digital Input 7	UINT32	8204	0x200C
Digital Input 8	UINT32	8206	0x200E

## 9.4 BACnet

The AcuLink 810 supports the BACnet protocol via the BACnet MS/TP and BACnet IP. The gateway can also be configured as a BACnet gateway, as well as a BBMD (BACnet Broadcast Messaging Device). The following section will provide an overview on configuring the BACnet protocol on the AcuLink 810 from the web interface.

### 9.4.1 BACnet MS/TP

In order to use the BACnet MS/TP, the protocol must be changed to BACnet for RS485 and/or USB devices. This can be changed from the **Interface Assignment** page under the **Protocols** tab.

**NOTE:** Users can have one port selected as Modbus and the other selected as BACnet.

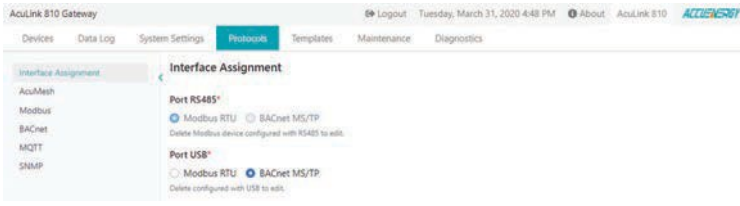

From the **Protocols** page select **BACnet**. In the BACnet page under the **Acquisitor** tab users can configure the BACnet MS/TP settings pertaining to RS485 and USB.

The following fields can be configured for BACnet MS/TP over both USB and RS485:

**Client APDU Timeout:** Is the time in seconds that the client will wait for a response after sending a request. The default time is 3 seconds, and the range is 250 milliseconds to 6 seconds.

**Client APDU Retries:** Is the number of time the client will retry a request when a response is not received. The default setting is 2, the range is from 0-10.

**MS/TP MAC Address:** Is used to address devices on the BACnet network, the default address is 1 and the range is 1-127.

**Max Master:** Defines the amount of allowable addresses (1-127) for the MS/TP master nodes on the network, the default is 127 and the range is 1-127.

**Max Info Frames:** Is the maximum amount of information frames sent to a node before it has to pass the token. The default is 1 and the range is from 1-100 information frames.

**Baud Rate:** Select the baud rate, the default is 19200 and the range is from 9600-11520.

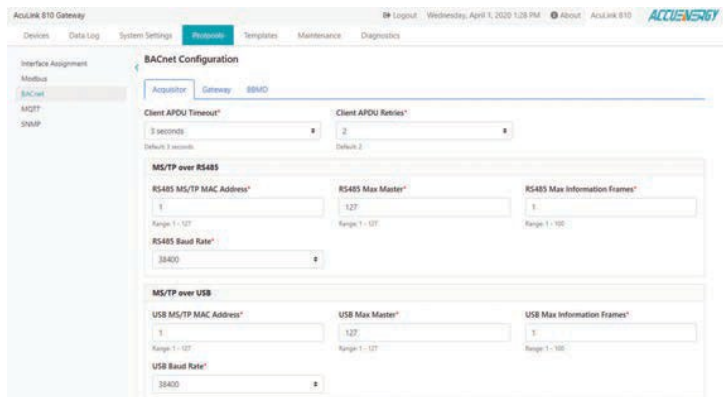

BACnet MS/TP via RS485

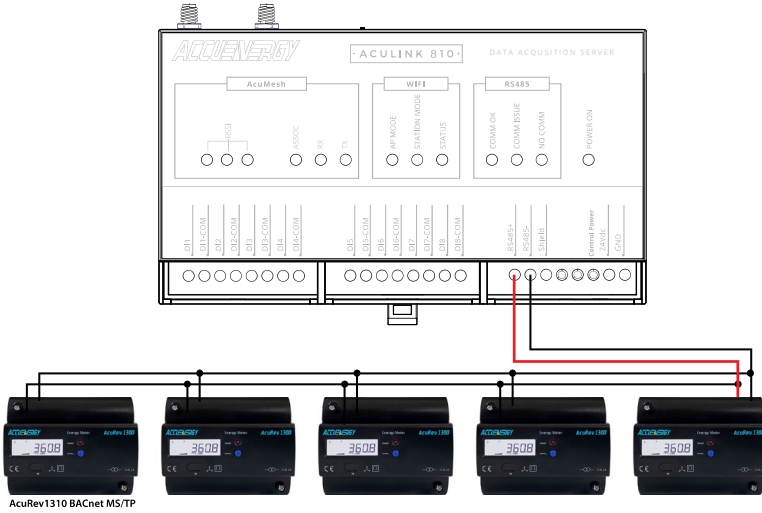

BACnet MS/TP via USB

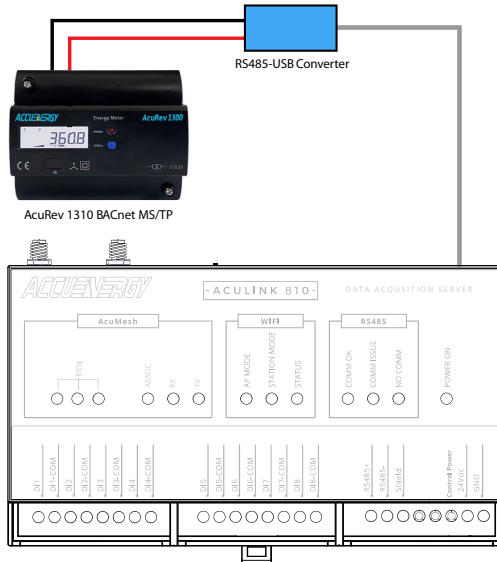

### 9.4.2 Adding BACnet MS/TP device

With the BACnet MS/TP protocol selected for either USB and/or RS485, users can add a BACnet device to the AcuLink 810 on the BACnet **Devices** page located under the **Devices** tab.

Click on **Add Device**, the following fields will need to be configured:

- **Device Name:** Enter the device name of the meter.
- **Serial Number:** Enter the serial number of the device, the serial number must be unique and consisting of only letters and numbers.
- **Device Model:** Select the device model from the drop-down list.
- **Port:** Users can select either RS485 or USB.
- **Device Instance:** Enter the device instance number, the range is 0-4194302. It must be unique in this AcuLink 810 device.

Click **Save** once all settings are entered correctly.

The screenshot shows the 'Add BACnet Device' form within the 'Devices' tab of the AcuLink 810 interface. The form includes the following fields and options:

- Device Name\***: Text input field containing 'AcuRev 1312'. Below the field, it states 'Maximum 40 characters'.
- Serial Number\***: Text input field containing 'E3T12345678'. Below the field, it states 'Must be unique in this AcuLink 810 device' and 'Maximum 20 characters'.
- Template\***: Dropdown menu with 'AcuRev 1310 BACnet' selected.
- Type\***: Dropdown menu with 'USB' selected.
- Device Instance\***: Text input field containing '26000'. Below the field, it states 'Range: 0 - 4194302'.

A green 'Save' button is located at the bottom of the form.

After the device is added, it can be found in the **BACnet Devices** section under the **Devices** tab.

Device Name	Interface	Protocol	Serial Number	Status	Alarms	Action
WEB2_163	Ethernet	BACnet IP	163	ON	1	[Action]
WEB2_94	Ethernet	BACnet IP	294	ON	0	[Action]
Acuvim_L_V3 BACnet	Ethernet	BACnet IP	LV3BACnet	ON	0	[Action]

**NOTE:** After adding a new device to the gateway it may take up to 3-4 minutes for the status to show 'ON'. If after 3-4 minutes the device is showing an 'OFF' status, double-check the configuration settings to ensure everything is set correctly.

If users need to change the configuration of an added device, they can simply click on the device and then select the **Configuration**. From this page users can re-configure the device name, port type, and Device Instance.

AcuLink 810 Gateway

Devices | Data Log | System Settings | Protocols | Templates | Maintenance | Diagnostics

Dashboard  
Alarm Logs  
Modbus Devices  
BACnet Devices  
MBus Devices  
Digital Inputs

**BACnet Device - 163**

Reading | Alarm | Configuration

**Device Name\***  
  
 Maximum 40 characters

**Template\***

**Type\***

**Device Instance\***  
  
 Range: 0 - 4194302

### 9.4.3 BACnet IP

The AcuLink 810 supports BACnet IP devices, users must configure and enable BACnet IP from the **BACnet** page in the **Protocols** menu.

**BACnet IP Client Enable:** Enable BACnet IP.

# AcuLink 810 Data Acquisition Server

**BACnet IP Client Interface:** Select which interface the BACnet IP network is on, users can select Ethernet 1, Ethernet 2, or WiFi.

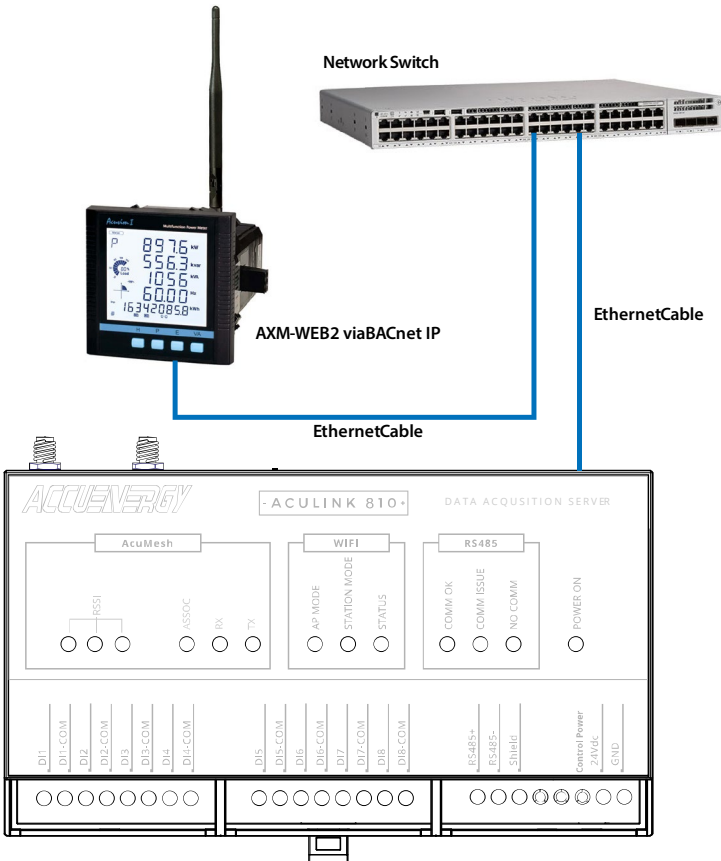



### 9.4.4 Adding BACnet IP device

With the BACnet IP enabled, users can add a **BACnet device** to the AcuLink 810 on the BACnet **Devices** page located under the Devices tab.

Click on Add Device, the following fields will need to be configured:

- **Device Name:** Enter the device name of the meter.
- **Serial Number:** Enter the serial number of the device, the serial number must be unique and consisting of only letters and numbers.
- **Template:** Select the device model from the drop-down list.
- **Type:** Select the type as IP.
- **Port:** Enter in the BACnet port configured for the device, the range is from 47808-49000.
- **Device Instance:** Enter the device instance number, it must be unique in this AcuLink 810 device. The range is 0-4194302.

**NOTE:** Ensure that BACnet IP Client is enabled in the BACnet Configuration page in order to add a BACnet IP device to the AcuLink 810.

Click on **Save** once all fields are configured.

AcuLink 810 Gateway

Devices | Data Log | System Settings | Protocols | Templates | Maintenance | Diagnostics

Dashboard  
Alarm Logs  
Modbus Devices  
BACnet Devices  
MBus Devices  
Digital Inputs

#### Add BACnet Device

**Device Name\***  
BACnet IP TEST  
Maximum 40 characters

**Serial Number\***  
IP  
Must be unique in this AcuLink 810 device  
Maximum 25 characters

**Template\***  
AXM-BIP

**Type\***  
IP

**Device Port\***  
47808  
Range: 47808 - 49000

**Device Instance\***  
810  
Range: 0 - 4194302

Save

After the device is added, it can be found in the **BACnet Devices** section under the **Devices** menu.

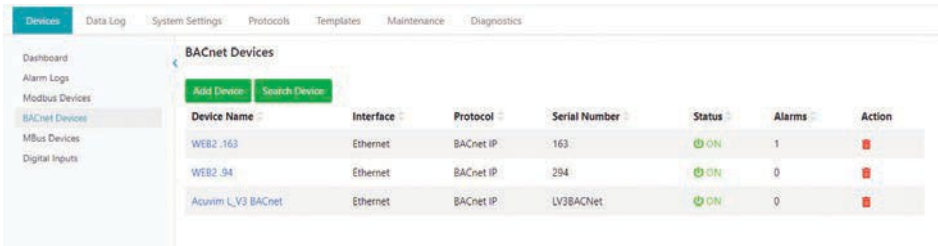

**NOTE:** After adding a new device to the gateway it may take up to 3-4 minutes for the status to show 'ON'. If after 3-4 minutes the device is showing an 'OFF' status, double-check the configuration settings to ensure everything is set correctly.

If users need to change the configuration of an added device, they can simply click on the device and then select the **Configuration**. From this page users can re-configure the device name, port type, and Device Instance and Device port.

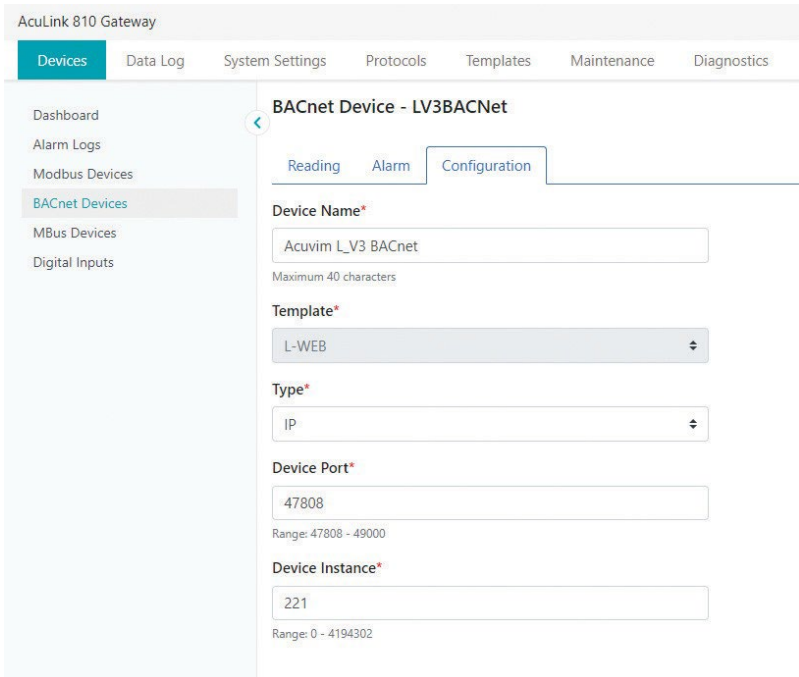

## 9.4.5 Search BACnet Device

The AcuLink 810 supports a search function that allows users to add devices to the AcuLink 810 automatically by searching the BACnet network. This feature can be found on the **BACnet Device** page under the **Device** tab.

Click on **Search Device**, the following search criteria will need to be specified:

**Interface:** Users can select Ethernet, RS485, or USB for the device search.

**NOTE:** In order to use RS485 or USB for search ensure that the interface assignment is selected as BACnet. Also in order to use Ethernet or WiFi in the BACnet search ensure that BACnet IP is enabled on the AcuLink 810.

**Search From (Device Instance):** Enter the starting instance number in the search, the range is 0-4194302.

**Search To (Device Instance):** Enter the ending instance number in the search, the range is 0-4194302.

Click on **Scan** once the search criteria is entered in correctly.

The screenshot shows the 'Scan BACnet Device' configuration page in the AcuLink 810 Gateway web interface. The page has a top navigation bar with 'Logout', 'Wednesday, April 1, 2020 4:51 PM', 'About', 'AcuLink 810', and the 'ACCUENERGY' logo. Below the navigation bar is a menu with 'Devices' selected, and sub-menus for 'Data Log', 'System Settings', 'Protocols', 'Templates', 'Maintenance', and 'Diagnostics'. On the left, a sidebar menu lists 'Dashboard', 'Alarm Logs', 'Modbus Devices', 'BACnet Devices' (highlighted), 'MBus Devices', and 'Digital Inputs'. The main content area is titled 'Scan BACnet Device' and contains the following fields:
 

- Interface\***: A dropdown menu with 'Eth' selected.
- Port\***: A text input field containing '47808'.
- Search From (Device Instance)\***: A text input field containing '0'.
- Search To (Device Instance)\***: A text input field containing '4194302'.

 Below each input field is a small text label indicating the range: 'Range: 1 - 65335' for Port, 'Range: 0 - 4194302' for Search From, and 'Range: 0 - 4194302' for Search To. A 'Back To Device List' button is located in the top right corner of the main content area.

**NOTE:** Depending on the range and amount of devices in the network the search may take several minutes to complete.

Users can individually add the found devices to the BACnet device list after the scan is complete. In order to add the BACnet device the template must be added and installed on to the AcuLink 810. For more information on BACnet template see section 7.4 of this User's Manual.

If a device is found with a Device Instance that is already added to the gateway the search will display **Conflict**.

If a device is found that is already added the search will display **Added**.

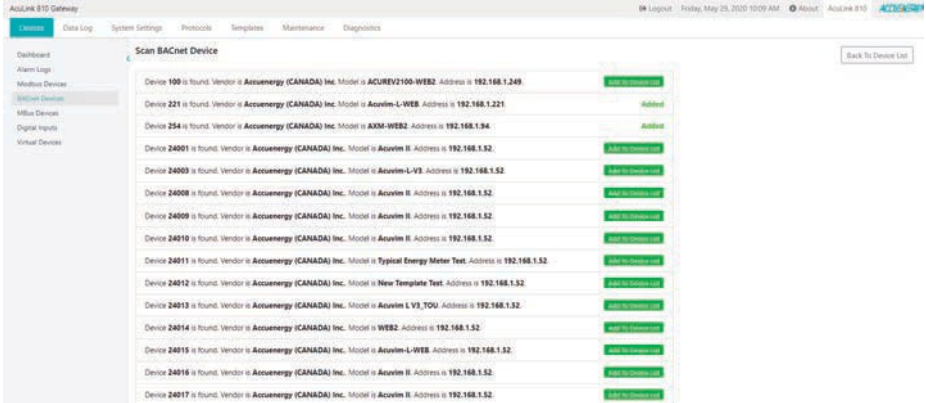

## 9.4.6 BACnet Gateway

AcuLink 810 can also work as a BACnet gateway device allowing the AcuLink 810 to read both Modbus and BACnet devices simultaneously in a BACnet network. Users have the ability to have both Modbus and BACnet devices simultaneously via USB and RS485 ports on the AcuLink 810, as well as both Modbus TCP, BACnet IP, and MBus devices.

To configure the BACnet gateway setting click on the **Protocols** tab and select BACnet. From the BACnet page select the **Gateway** tab. The following fields can be configured for the BACnet gateway settings:

**Gateway Enable:** Select **Enable** to set the 810 as a BACnet gateway.

**UDP Port:** The default port is 47808, users can configure from 47808-49000.

**Device Object Name:** Users can configure the object name for the gateway.

**Device Instance:** Configure a unique device instance number for the AcuLink 810.

**Network Number:** The network number identifies a network within a BACnet system. The default number is 1 and the range is from 1-65534.

**Advertised APDU Timeout:** The default APDU timeout is 3 seconds, and the range is from 3-60 seconds.

**Advertised APDU Retries:** The default APDU retry is 2, and the range for the setting is 0-10.

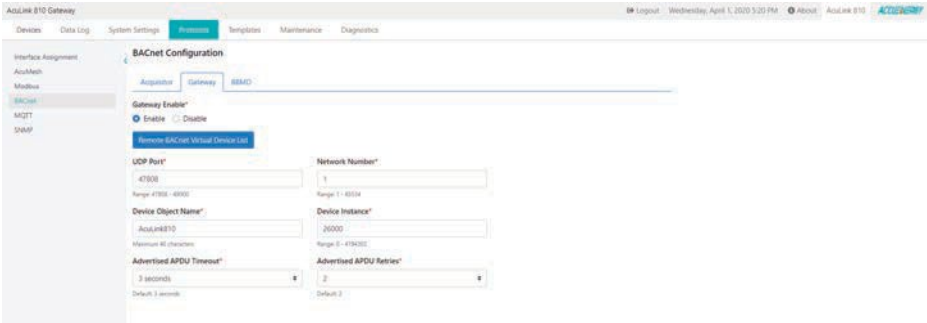

The **Remote BACnet Virtual Device List** allows users to see what devices are accessible via the BACnet gateway. The list provides the user with the device name, serial number, protocol that it is using via the 810 and the instance number assigned to it in the BACnet network. The BACnet virtual list can be exported as a .csv file for user reference.

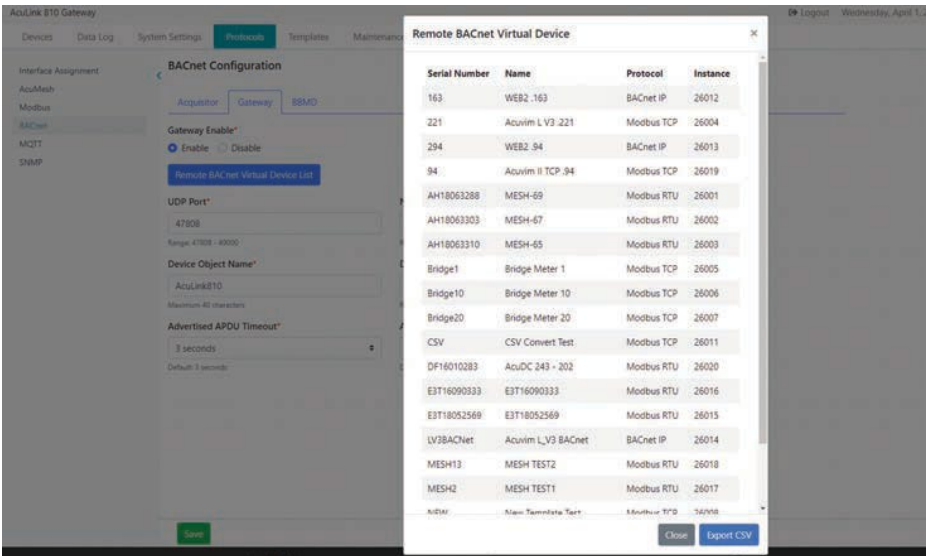

### 9.4.7 BBMD

In BACnet IP systems there are several broadcast messages that are used, however, these messages are normally blocked since most BACnet IP devices are connected via IP routers. BBMD stands for BACnet Broadcast Management Device and is used to allow for IP broadcasting to locate and communicate with other BACnet devices.

**BBMD Mode:** Users can select the following options for BBMD:

- **Allowing incoming FDR:** Foreign Device Registration allows the AcuLink 810 to send its broadcast message to a BBMD.
- **Full BBMD:** allows the AcuLink to send broadcast messages to other BBMDs.
- **Disable:** Disables BBMD
- **BBMD Address List:** Users can enter the IP address of the BBMD.

The screenshot shows the 'AcuLink 810 Gateway' web interface. The top navigation bar includes 'Devices', 'Data Log', 'System Settings', 'Protocols' (selected), 'Templates', 'Maintenance', and 'Diagnostics'. On the left, a sidebar lists 'Interface Assignment' options: 'AcuMesh', 'Modbus', 'BACnet' (selected), 'MQTT', and 'SNMP'. The main content area is titled 'BACnet Configuration' and has three tabs: 'Acquisitor', 'Gateway', and 'BBMD' (selected). Under the 'BBMD' tab, there is a 'BBMD Mode\*' dropdown menu currently set to 'Allowing incoming FDR'. Below this is a 'BBMD Address List' section with an 'Add Address' link and a text input field containing 'Enter Address 1' and a 'Remove' button. A note below the input field states 'Must be ip address'.

### 9.5 MQTT Protocol

The AcuLink 810 supports the MQTT protocol where the gateway can publish device data to a subscriber using an MQTT broker. The MQTT broker is a central server where all MQTT clients would connect to. The broker/server manages all message topics and updates new messages to all clients that are subscribed to a particular topic (AcuLink 810). All related MQTT settings can be configured in the **MQTT** page under the **Protocols** tab.

## 9.5.1 MQTT General Settings

Under the **General** tab in the MQTT page, users can enable the MQTT protocol and configure the broker settings.

**Enable MQTT:** Select Enable to use MQTT protocol.

**Broker Address:** Enter the broker address of the MQTT server.

**Broker Port:** Enter the port number for the MQTT Broker.

**Client ID:** Enter the Client ID for the AcuLink 810; must be a unique ID number.

**Keep Alive:** The client communicates a time interval in seconds to the broker, “Keep-Alive” is the maximum length of time in seconds that the broker and the client cannot communicate with each other.

**Timeout:** Enter the timeout setting time in seconds.

Once all settings are configured click **Save**. The connection to the broker can be tested by using the **Test MQTT** button.

The screenshot displays the 'MQTT Configuration' page within a web interface. The navigation menu on the left includes 'Interface Assignment', 'AcuMesh', 'Modbus', 'BACnet', 'MQTT', and 'SNMP'. The main content area is titled 'MQTT Configuration' and has several tabs: 'General', 'User Credential', 'SSL/TLS', 'Last Will and Testament', and 'Devices to Publish'. The 'General' tab is active, showing the following settings:

- MQTT Enable\***: Radio buttons for 'Enable' (selected) and 'Disable'.
- Broker Address\***: Text input field containing 'test.mosquitto.org'.
- Broker Port\***: Text input field containing '1883'.
- Client ID\***: Text input field containing '1'.
- Keep Alive\***: Text input field containing '60', with a seconds icon to the right.
- Timeout\***: Text input field containing '30', with a seconds icon to the right.
- Clean Session\***: Radio buttons for 'Yes' and 'No' (selected).

At the bottom of the configuration area, there are two buttons: a yellow 'Test MQTT' button and a green 'Save' button.

### 9.5.2 MQTT Authentication

The User Credential tab allows users to configure a User Name and Password authentication if the broker is able to support it.

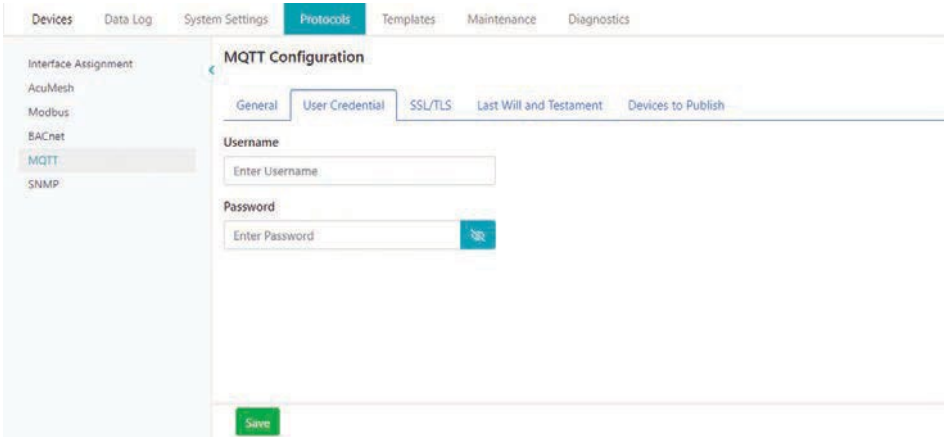

### 9.5.3 MQTT Encryption

The **SSL/TLS** tab allows users to use the MQTT protocol with encryption.

In this page users will be able to upload the required certificate and key files.

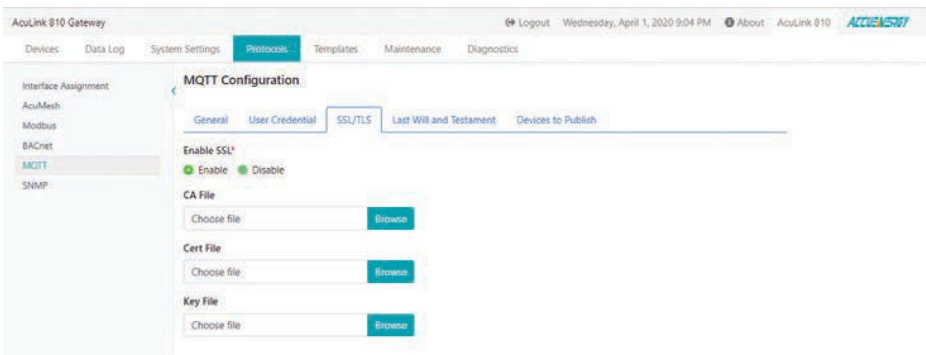



### 9.5.4 Last Will & Testament

The AcuLink supports Last Will and Testament messages via the MQTT protocol. These settings can be configured under the **Last Will & Testament** tab.

The last will and testament message is used to notify other clients regarding other disconnected clients. The message is an MQTT message that contains a topic, a QoS level and a payload.

**Topic:** Refers to the path used to access the MQTT message.

**QoS:** Stands for Quality of Service and refers to the reliability of the message delivery between the publisher and subscriber. There are three types of quality of service:

1. **QoS 0** - is the lowest level, and is defined as “at most once” delivery. This level has the fastest message delivery but the success rate of delivery is not reliable.
2. **QoS 1** - is defined as “at least once” delivery. These types of messages are reliable and are guaranteed, however the message may be sent as duplicates several times.
3. **QoS 2** - Is the highest level, and is defined as “exactly once” delivery. These messages are more reliable and are guaranteed to be sent once without any duplicates. This type of messaging sends the most reliable message however it has a slower message delivery. Each client can optionally specify its own LWT message when it connects to a broker. The broker stores this message so that if the client disconnects ungracefully, the broker will send the disconnected client’s LWT message to all the other clients that are subscribed to that last will message topic.

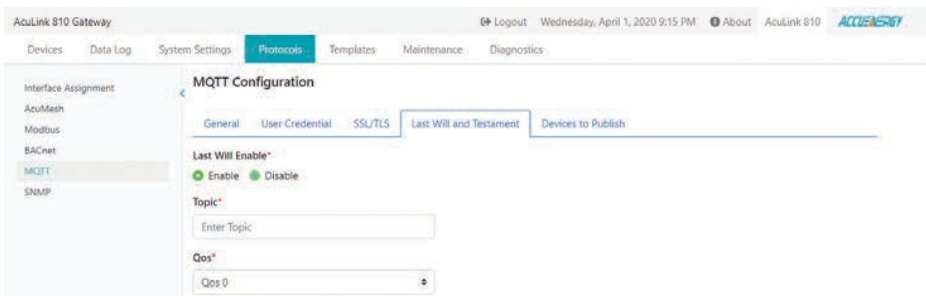

## 9.5.5 Device Publishing

Under the **Devices to Publish** tab users can configure the sending interval and devices data they want to publish to the broker.

**All Meters Use One Topic:** If selected as **Yes** users can use one topic for reading all published devices, however if **No** is selected users will need to configure a base topic.

**Topic:** Users will enter in the Topic used to read all devices.

**Base Topic:** Users can enter in the Topic, is usually a base topic followed by the serial number of the device.

**QoS:** Users can configure the quality of service level, where Qos 0 is the lowest level and Qos 2 is the highest level.

**Retained:** Users have the option retain messages or not. If a client retains messages that was published to topic, a second client that is subscribed to the same topic will be able to see the retained message.

**Interval:** Users can select the publishing interval, the range is from 10-600 seconds.

**Payload Format:** Users can select from two different payload formats.

**Select Devices to Publish:** Users can select Modbus RTU/TCP devices, BACnet MS/TP or IP devices, MBus devices and the Digital Input counter to publish to the MQTT broker.

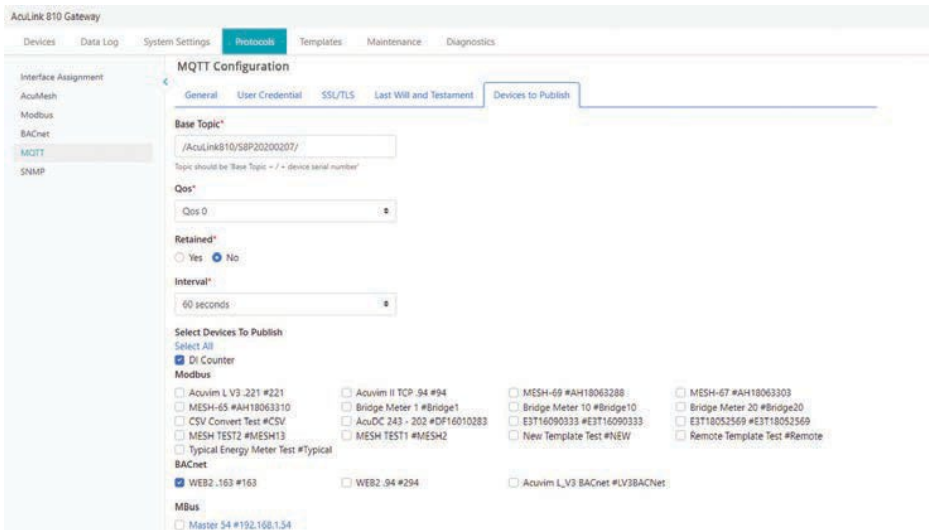

## 9.6 Azure IoT

The **Azure** Internet of Things (**IoT**) is a collection of Microsoft cloud services that allow the user to have reliable device to cloud communication. **Azure IoT hub** is a managed **IoT** service which is hosted in the cloud and allows for bi-directional communication between **IoT** applications and the devices. This cloud-to-device connectivity means that you can receive data from your devices, but you can also send commands back to the device. The AcuLink 810 supports **Azure IoT** device posting where users can send Modbus, BACnet, MBus, and Virtual Devices to the IoT Hub.

Once connected on Azure, users can also configure settings on the AcuLink 810 from Azure via device twin.

The following settings need to be configured.

**Azure IoT Enable:** Will allow users to enable/disable Azure IoT.

**Primary Connection String:** Enter in the primary connection string for the IoT Hub.

**Secondary Connection String:** Enter in the secondary connection string for the IoT Hub.

**Interval:** Select how often to post to the IoT Hub, the range is from 10-600 seconds.

**Enable SSL:** When 810 connect to Azure X509 IoT device/IoT Edge device, Users can enable SSL where they can upload their own certificate and key file for encryption posting.

**Select Devices to Publish:** Users can select Modbus RTU/TCP devices, BACnet MS/TP or IP devices, MBus devices and the Digital Input counter to publish to the Azure IoT Server.

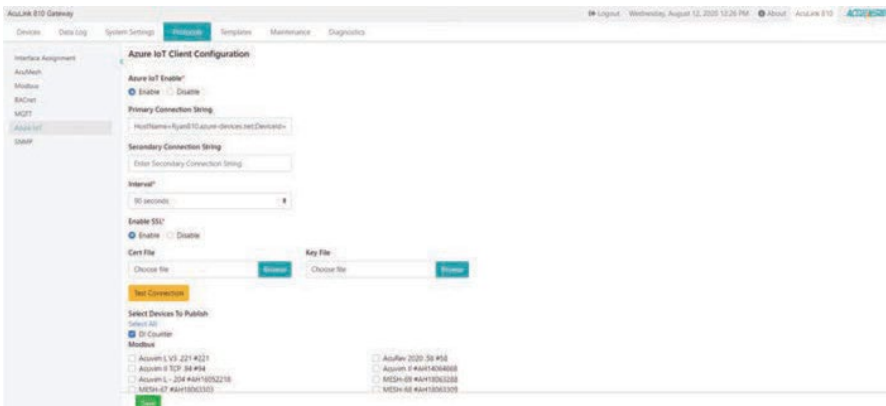

### 9.6.1 Creating Azure IoT Device on Azure Portal Server

1. Sign in to the Azure Portal (<https://portal.azure.com>).
2. From the Azure homepage, select the + **Create a resource** button, and then enter IoT Hub in the **Search the Marketplace** field.
3. Select **IoT Hub** from the search results, and then select **Create**.
4. On the **Basics** tab, complete the fields as follows:
  - **Subscription:** Select the subscription to use for your hub.
  - **Resource Group:** Select a resource group or **create a new** one. To create a new one, select Create new and fill in the name you want to use. To use an existing resource group, select that resource group. For more information, see Manage Azure Resource Manager resource groups.
  - **Region:** Select the region in which you want your hub to be located. Select the location closest to you. Some features, such as IoT Hub device streams, are only available in specific regions. For these limited features, you must select one of the supported regions.
  - **IoT Hub Name:** Enter a name for your hub. This name must be globally unique. If the name you enter is available, a green check mark appears.

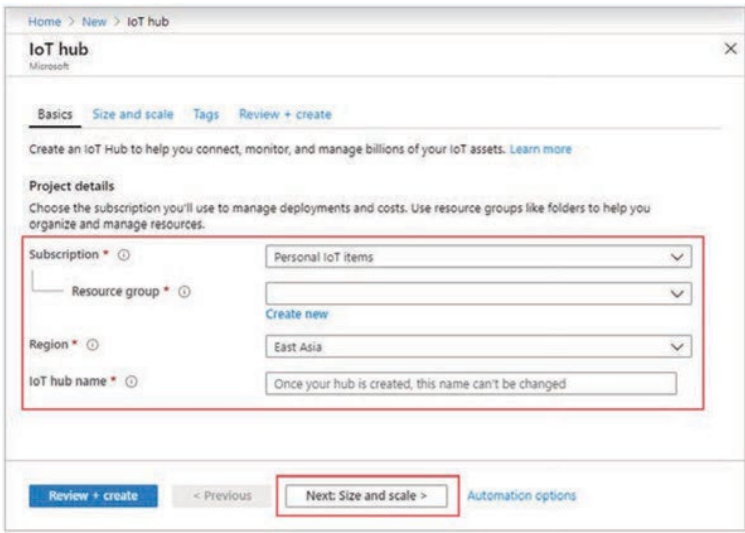

## 9.6.2 Create an IoT devices /IoT Edge device in the Azure portal

In your IoT Hub in the Azure portal, IoT Edge devices are created and managed separately from IOT devices that are not edge enabled.

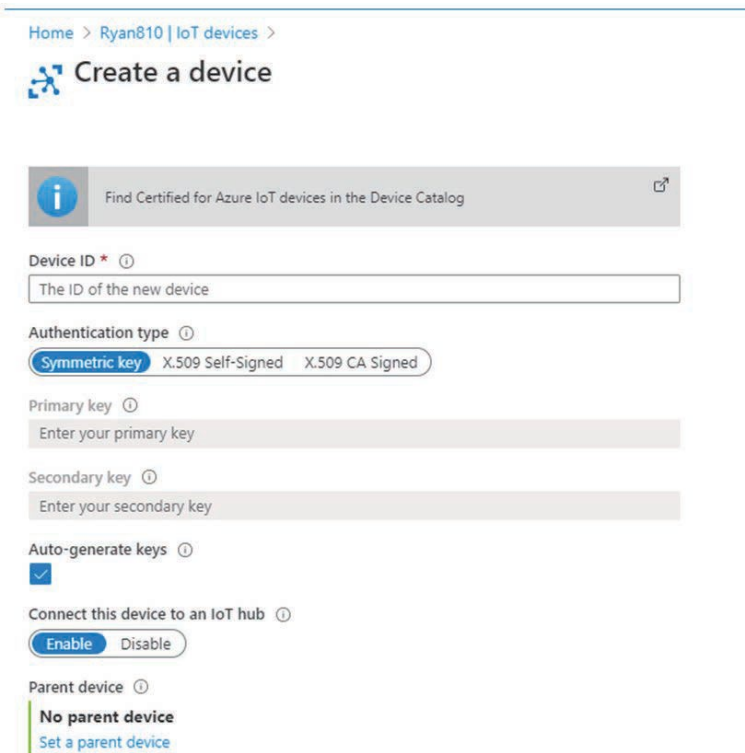

1. Sign in to the Azure Portal and navigate to your IoT hub.
2. In the left panel, select **IoT devices/ IoT Edge** from the menu.
3. Select **New/Add an IoT Edge device**.
4. Provide a descriptive device ID. Use the default settings to auto-generate authentication keys and connect the new device to your hub.
5. Select authentication type:

You can select Symmetric key or X.509 CA signed.





Home > Ryan810 | IoT devices >

### Create a device

 Find Certified for Azure IoT devices in the Device Catalog 

Device ID \*   
The ID of the new device

Authentication type   
**Symmetric key** X.509 Self-Signed X.509 CA Signed

Primary key   
Enter your primary key

Secondary key   
Enter your secondary key

Auto-generate keys 

Connect this device to an IoT hub   
**Enable** Disable

Parent device   
**No parent device**  
[Set a parent device](#)

Home > Ryan810 | IoT devices

Search (Ctrl+F) + New Refresh Delete

View, create, delete, and update devices in your IoT Hub.

Field: select or enter a property name Operator: = Value: specify constraint value

+ Add a new clause

Query devices Switch to query editor

DEVICE ID	STATUS	LAST STATUS UPDATE (UTC)	AUTHENTICATION TYPE	CLOUD TO DEVICE MESSAGE COUNT
ACU-810-SAS	Enabled	...	Sas	0
AcuLink810-X300	Enabled	...	CertificateAuthority	0

Home > myIoT Hub - IoT Edge

myIoT Hub - IoT Edge

Search (Ctrl+F) + Add an IoT Edge device Create Deployment Create Layered Deployment Refresh Delete

Settings

- Shared access policies
- Pricing and scale
- IP Filter
- Certificates
- Built-in endpoints
- Fallover
- Properties
- Locks
- Export template

Explorers

- Query explorer
- IoT devices
- IoT Edge
- IoT device configuration

Automatic Device Management

- IoT Edge
- IoT device configuration

Messaging

- File upload
- Message routing

Deploy Azure services and solution-specific code to on-premises devices. Use IoT Edge devices to perform compute and analytics tasks on data before it's sent to the cloud.

IoT Edge devices IoT Edge deployments

IoT Edge devices

Field: Select or enter your own Operator: = Value:

+ Add new clause

Query devices Switch to query editor

Device ID	Runtime Response	IoT Edge Module Count	Connected Client Count	Deployment Count
<input type="checkbox"/> IoTEdgeDevice	OK	2	0	0
<input type="checkbox"/> GatewayDevice	OK	3	1	3

### 9.6.3 Retrieving the connection string in the Azure portal

SAS IoT device/IoT Edge device:

When you're ready to set up your device, you need the connection string that links your physical device with its identity in the IoT hub.

1. From the **IoT devices/IoT Edge** page in the portal, click on the device ID from the list of IoT Edge devices.
2. Copy the value of either **Primary Connection String** or **Secondary Connection String**.

X.509 IoT device/IoT Edge device:

Connection string is defined as:

```
"HostName=<host_name>;DeviceId=<device_id>;x509=true"
```

### 9.6.4 Configure AcuLink 810 from Azure

AcuLink810 support device twins desired properties to synchronize device configuration or conditions, where the 810 can configure the NTP and Azure IoT configuration from the Azure portal.

The configuration is defined in desired properties:

```
{
  "properties": {
    "desired": {
      "ntpConfig": {
        "enable": true,
        "ntpServer1": "0.us.pool.ntp.org",
        "ntpServer2": "",
        "ntpServer3": "",
        "timeZone": "America/Toronto",
        "lastUpdateTimestamp": 1595876093
      }
    }
  }
}
```

```
    },  
    "azureConfig": {  
        "azureIoTEnable": true,  
        "primaryConnectionString": "HostName=AcuLink810.azure-devic  
es.net;DeviceId=810pc;x509=true",  
        "secondaryConnectionString": "",  
        "sslEnable": true  
    },  
    "existingProperty": "otherNewValue",  
    "otherOldProperty": null  
}  
}  
}
```

### 9.7 SNMP

The AcuLink 810 supports the Simple Network Management Protocol (SNMP) which allows for reporting the 810 device data to the management station. The SNMP settings can be found on the **SNMP** page under the **Protocols** tab.

**SNMP Enable:** Select **Enable** for the SNMP protocol.

**SNMP Version:** Users can select either SNMPv2c or SNMPv3.

**Version 2:** requires a read only community string to be configured.

**Version 3:** requires authentication and privacy protocol.

**Port:** The default SNMP port is 161, the range is 16100-16199.

The AcuLink also supports SNMP trap notifications, where the user can receive a trap notification for any alarms that are triggered for devices on the AcuLink.

**Trap Enable:** Select enable for trap notifications.



**Trap Target 1-4:** Users can configure up to 4 trap targets, where the trap targets must be an IP address.

**Buffer Size:** Enter the size of the buffer for the amount of notifications will be stored before being sent to the management station. A maximum of 30 notifications can be stored.

**Report Hold Time:** Enter the time in seconds for how long the notification will be in queued before it gets sent to the management station. By default, this setting is configured to 0 so the notification will be sent immediately after an event occurs. This setting could be configured from 0-30 seconds.

The screenshot shows the 'SNMP' configuration page in the AcuLink 810 Gateway web interface. The page is titled 'SNMP' and has a 'Save' button at the bottom. The configuration options are as follows:

- SNMP Enable:** Radio buttons for 'Enable' (selected) and 'Disable'.
- SNMP Version:** A dropdown menu set to 'v1' and a 'Port' field set to '161'. Below this is a note: 'Default V1 Range: 16100 - 16199'.
- SNMP Community:** A section titled 'SNMP Community' with a text input field for 'Enter R0 Community'.
- Trap Enable:** Radio buttons for 'Enable' (selected) and 'Disable'.
- Trap Targets:** Four sections for 'Trap Target 1' through 'Trap Target 4'. Each has a text input for 'Trap Target X' and a note 'Must be an address'.
- Report Buffer Size:** A text input field set to '30' with a note 'Range: 0 - 30'.
- Report Hold Time:** A text input field set to '0' with a note 'Range: 0 - 300'.
- Buttons:** A blue 'Download MIB File' button is located below the 'Report Buffer Size' field. A green 'Save' button is at the bottom of the page.

### 9.7.1 MIB File

The SNMP MIB file includes all the device data objects required to read the device on a SNMP system. The MIB file of the AcuLink 810 can be downloaded directly from the web interface in the **SNMP** page. When downloading the SNMP file it will be downloaded as a zip folder including the individual MIB files are all device models on the AcuLink 810.

This close-up view shows the 'Report Buffer Size' and 'Report Hold Time' configuration fields. The 'Report Buffer Size' field contains the value '30' and has a range of '0 - 30'. Below it is a blue 'Download MIB File' button. The 'Report Hold Time' field contains the value '0' and has a range of '0 - 300'. A green 'Save' button is located at the bottom of the configuration area.

## 9.8 MBus

The AcuLink supports MBus devices, where the user can add MBus devices to the AcuLink 810 via an Mbus TCP/IP master. Mbus meters are typically used for reading water, gas and electricity.



### 9.8.1 Adding MBus Device

To add an MBus device select **MBus** under the **Devices** tab. Users will first need to add the MBus master device, click on **Add Device**.

Enter in the following:

**Master Name:** Enter the master name.

**Master IP Address:** Enter the IP address of the master device.

**Master Port:** Enter the port number for the master device, the range is 1-65535.

Click on **Save** once complete.

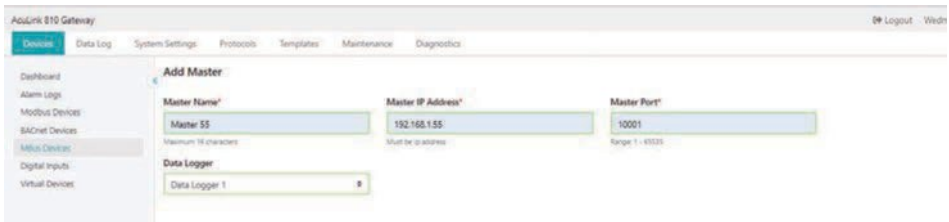

The added master will show up on the MBus Device page.



Alternatively Users can Search for the master device. Click on **Search Master**.

The following is required for the search criteria:

**Start IP Address:** Enter the starting IP range for the search.

**End IP Address:** Enter the ending IP range for the search.

**Master Port:** Enter the master port, range is 1-65535.

Click on **Scan** once the search criteria is completed.

When the scan has completed all masters discovered in the search will appear, users have the option to add them individually or can use the add all button to add all discovered MBus masters.

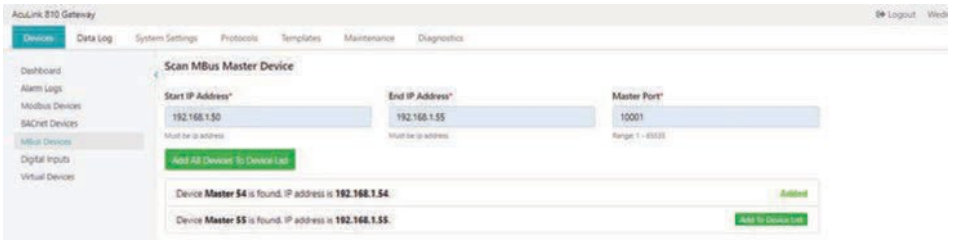

To add the MBus slave devices click on the Master from Mbus page, users will be redirected to the following page.

From this page users can change the Master name, however the IP and master port cannot be modified. From here users can add Mbus devices to the AcuLink 810.

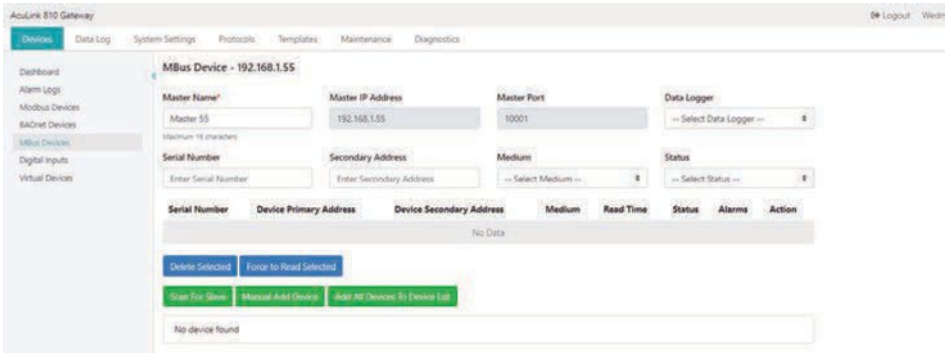

## Scanning for Mbus Devices

Users can run a scan to search for all available Mbus slaves on the master by selecting **Scan For Slave**.

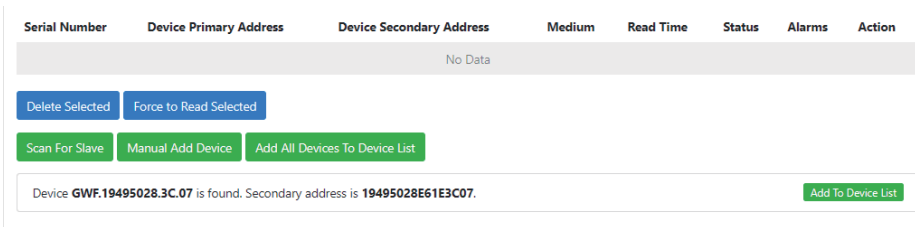

Once the slave device is added it will show up on this page under the **Added Slaves** section. The serial number, device primary address, and device secondary address will be displayed. The status ON will indicate the meter is online, OFF will indicate the meter is offline.

Users can delete the device from this page as well by clicking on the delete button under the Action column. If there are several Mbus devices that have been added, users can use the filter credentials to sort and filter the Mbus devices, users can sort and filter by serial number, secondary address, medium, and status.

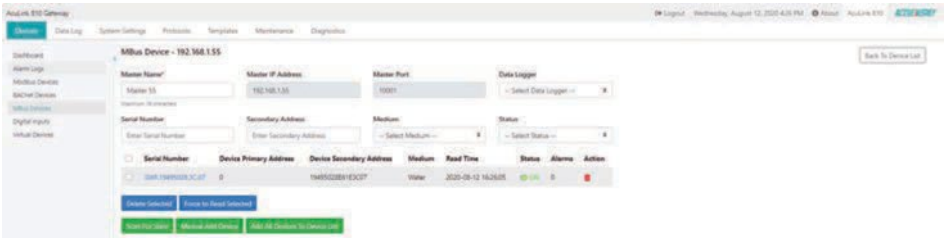

Users can perform a force read for the selected Mbus devices, this will provide users with the latest data from the device. The read time will be updated to notify users of the read.



### Adding Mbus Device Manually

Users can also add Mbus devices manually, using this method the secondary address is required. Once the address is entered, click on **Add**.

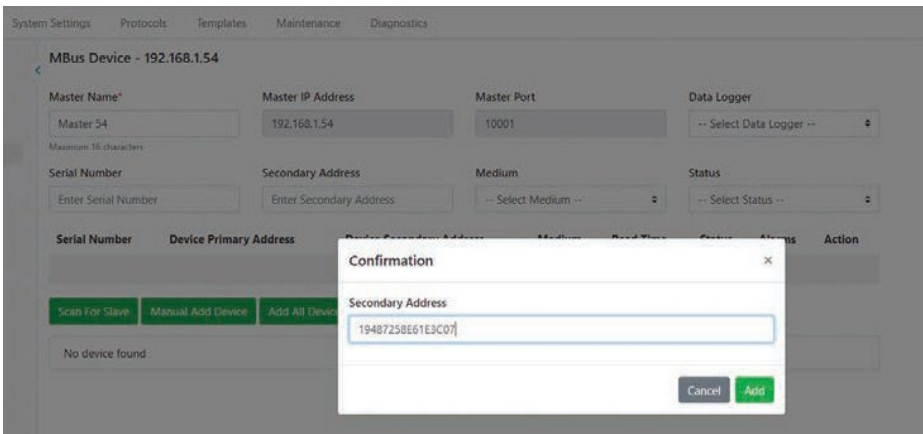

## Data Logging for MBus devices

Logging for MBus devices can be done directly from the MBus device page. Under the **Data Logger** drop down menu, users can select which data logger to use for the MBus device. Alternatively users can also specify which MBus devices to log under the Data Loggers configuration page (Data Log>Data Loggers).

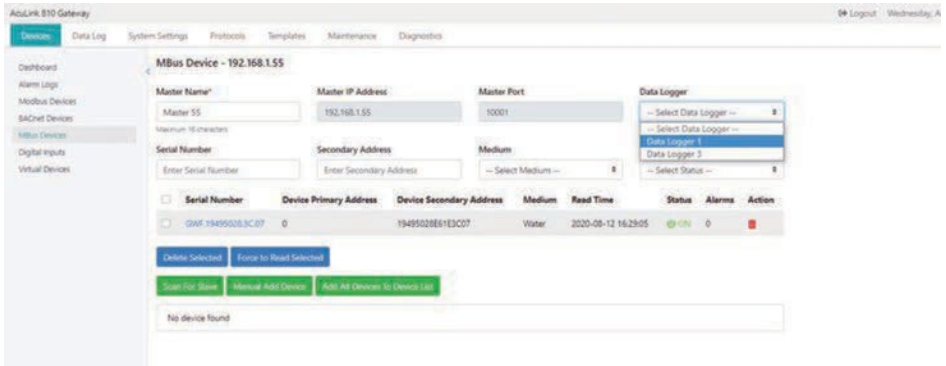

## 9.9 Virtual Device

The AcuLink 810 supports the creation of a virtual device which allows users to create a device based on a certain calculations/formulas of devices already added to the AcuLink 810. Select **Virtual Devices** under the **Devices** tab and click on **Add Virtual Device**.



Users will be required to enter a Device name for the virtual device. Once the name is selected for the device click on **Add Virtual Parameter** to start creating and adding the virtual parameters.



### 9.9.1 Adding Virtual Parameter

The following settings will need to be configured in order to add the Virtual parameters.

- **Parameter Name** - Enter a parameter name for the virtual device.
- **Unit** - Enter the unit that will be used for the virtual parameter.
- **Parameter Type** - Can be selected as either Realtime or Accumulative.

**Calculated Meter Formula** - The meter formula can be created by clicking on the the **Select Device Parameter** button. This will allow users to select existing parameters from Modbus, BACnet and MBus devices already added to the AcuLink 810. Once users have the parameters selected from the existing device click on **Select**, users will notice the parameter is added into the meter formula bar. Users also have the option to add math functions to their calculated meter formula such as addition(+), subtraction(-), multiplication(\*), and division(/).

Users can add another parameter by to their Virtual device by clicking on the **Add Virtual Device Parameter**, and can have up to 50 Virtual Parameters per Virtual Device. Once all parameters are added, click on **Save**.

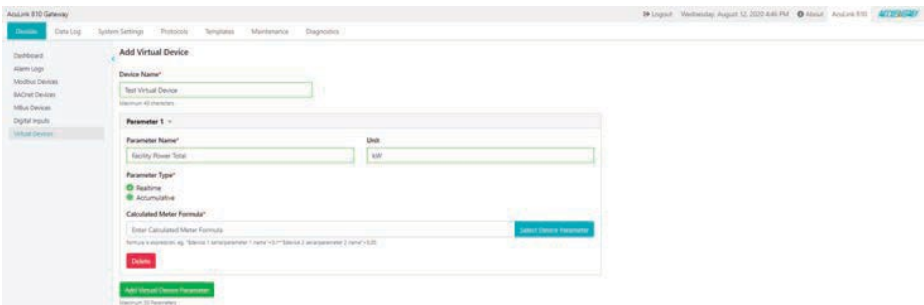

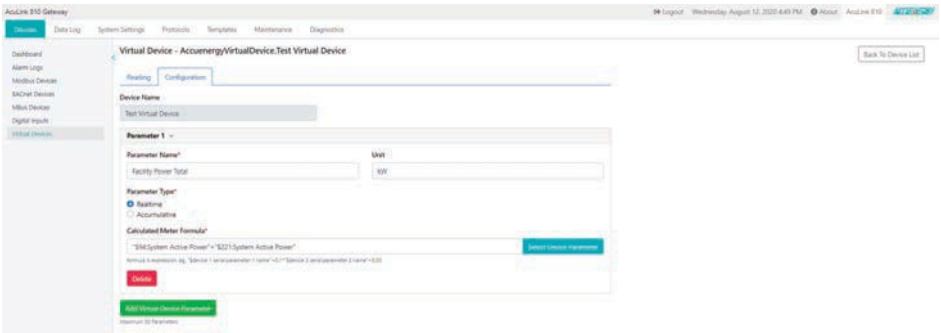
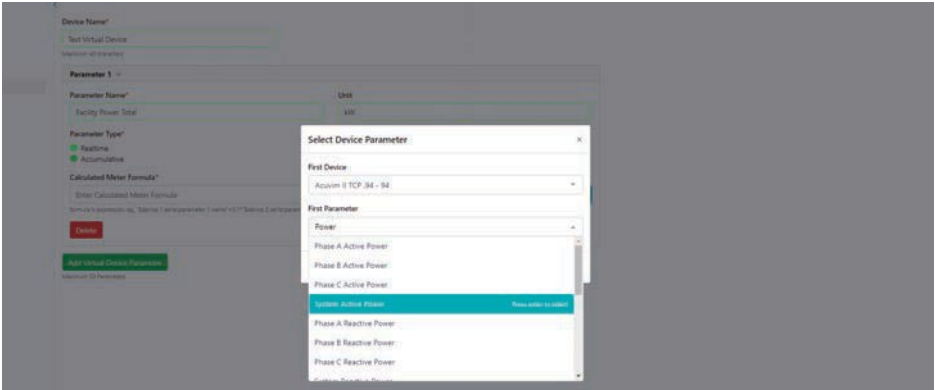

Once the device is created it can be seen from the Virtual device page, to view the readings click on the Virtual Device.

Under the **Readings** tab users can view the virtual device readings.



Users can edit the Virtual Device in the Configuration tab, from here the user can edit the parameter name, unit, parameter type, calculated meter formula, and also delete virtual parameters.



**NOTE:** The Virtual Device Name cannot be modified in the Configuration tab.

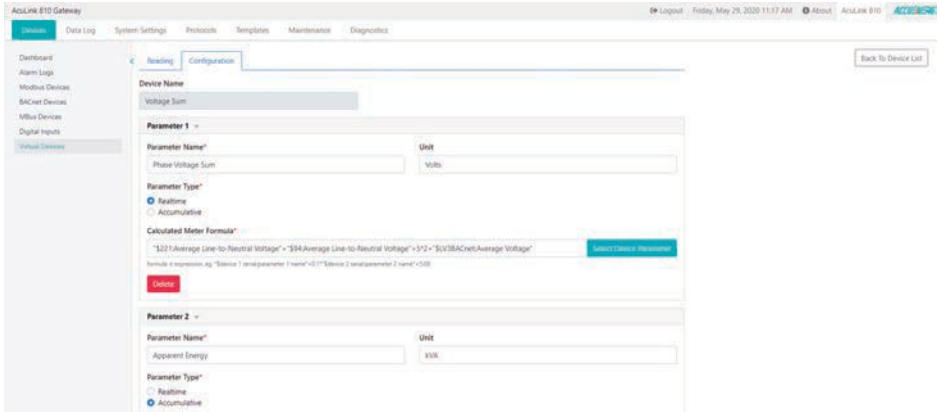

# Chapter 10: Device Readings

The device readings can be seen directly on the AcuLink 810 interface. The device data updates every minute on the interface. To view the device readings click on the **Devices** tab and select either **Modbus/BACnet Devices**.

Users can simply click on the device they wish to view the data under the **Readings** tab. Depending on the device users can click on the **Reading Type** drop-down menu and select different types of parameters to read from the device.

The screenshot shows the 'Modbus Device - 94' page in the AcuLink 810 Gateway. The 'Reading' tab is selected, and the 'Reading Type' is set to 'Energy'. A table displays various energy parameters and their values.

Parameter	Value
System Import Active Energy	20497.700305 kWh
System Export Active Energy	13802.200206 kWh
System Import Reactive Energy	18722.400279 kWh
System Export Reactive Energy	27981.600417 kWh
System Total Active Energy	34299.900511 kWh
System Net Active Energy	6695.500100 kWh
System Total Reactive Energy	46704.000696 kWh
System Net Reactive Energy	-9259.200138 kWh
System Apparent Energy	58140.100866 kWh
Phase A Import Active Energy	0.000000 kWh

For **Mbus Devices** users will need to first click on the Mbus master and then select the Mbus devices they wish to view the readings for.

The screenshot shows the 'Mbus Slave Device - GWF19495028E61E3C07' page in the AcuLink 810 Gateway. The 'Reading' tab is selected, and the 'Reading Type' is set to 'Readings'. A table displays two parameters and their values.

Parameter	Value
Fabrication number	19495028
Volume	0.171 m <sup>3</sup>

## 10.1 Parameter Definition

Users can use the **Parameter Definition** function to define each parameter on the list and let it display on the AcuLink 810 or on the data log.

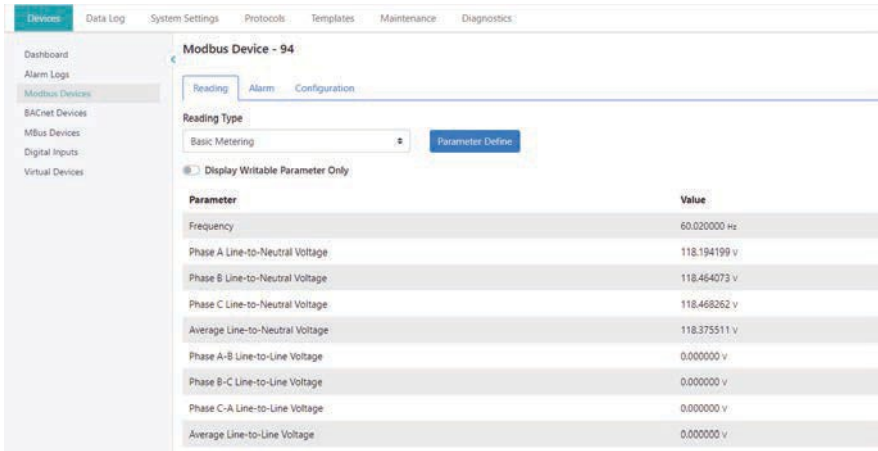

**Modbus Device - 94**

Reading Alarm Configuration

Reading Type

Basic Metering Parameter Define

Display Writable Parameter Only

Parameter	Value
Frequency	60.020000 Hz
Phase A Line-to-Neutral Voltage	118.194199 v
Phase B Line-to-Neutral Voltage	118.464073 v
Phase C Line-to-Neutral Voltage	118.468262 v
Average Line-to-Neutral Voltage	118.375511 v
Phase A-B Line-to-Line Voltage	0.000000 v
Phase B-C Line-to-Line Voltage	0.000000 v
Phase C-A Line-to-Line Voltage	0.000000 v
Average Line-to-Line Voltage	0.000000 v

Select the “Reading Type” then click the **Parameter Define**, the following page will show up.

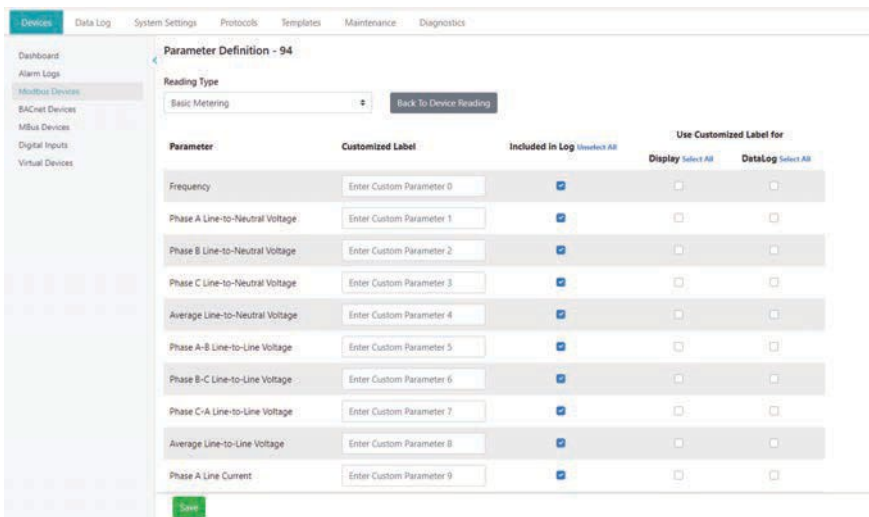

**Parameter Definition - 94**

Reading Type

Basic Metering Back to Device Reading

Parameter	Customized Label	Included in Log <small>Select All</small>	Use Customized Label for	
			Display <small>Select All</small>	Data Log <small>Select All</small>
Frequency	Enter Custom Parameter 0	<input checked="" type="checkbox"/>	<input type="checkbox"/>	<input type="checkbox"/>
Phase A Line-to-Neutral Voltage	Enter Custom Parameter 1	<input checked="" type="checkbox"/>	<input type="checkbox"/>	<input type="checkbox"/>
Phase B Line-to-Neutral Voltage	Enter Custom Parameter 2	<input checked="" type="checkbox"/>	<input type="checkbox"/>	<input type="checkbox"/>
Phase C Line-to-Neutral Voltage	Enter Custom Parameter 3	<input checked="" type="checkbox"/>	<input type="checkbox"/>	<input type="checkbox"/>
Average Line-to-Neutral Voltage	Enter Custom Parameter 4	<input checked="" type="checkbox"/>	<input type="checkbox"/>	<input type="checkbox"/>
Phase A-B Line-to-Line Voltage	Enter Custom Parameter 5	<input checked="" type="checkbox"/>	<input type="checkbox"/>	<input type="checkbox"/>
Phase B-C Line-to-Line Voltage	Enter Custom Parameter 6	<input checked="" type="checkbox"/>	<input type="checkbox"/>	<input type="checkbox"/>
Phase C-A Line-to-Line Voltage	Enter Custom Parameter 7	<input checked="" type="checkbox"/>	<input type="checkbox"/>	<input type="checkbox"/>
Average Line-to-Line Voltage	Enter Custom Parameter 8	<input checked="" type="checkbox"/>	<input type="checkbox"/>	<input type="checkbox"/>
Phase A Line Current	Enter Custom Parameter 9	<input checked="" type="checkbox"/>	<input type="checkbox"/>	<input type="checkbox"/>

Save

Users can check off which parameters they want included or create their own customized label.

- **Included in Log** - Select if the parameter needs to be included in the data log file.
- **Customized Label** - Where users can create a custom label for the parameter listed in the template.
  - Display - Display the customized label on the AcuLink 810 reading interface.
  - DataLog - Display the customized label on the AcuLink 810 data log file.

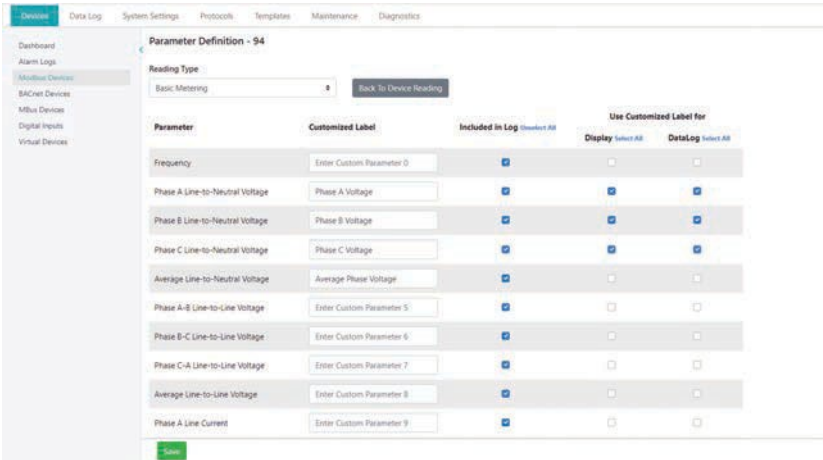

Click **Save** after everything is set up, then click on the **Back To Device Reading** button. In the readings page users will see their customized label implemented.

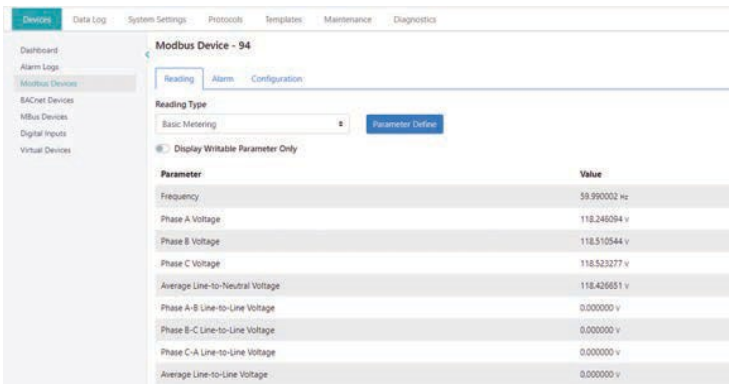

When downloading the data log file, the name in the header will be changed according to the custom label configured.

1	Time	Freq_Hz	Phase A Voltage	Phase B Voltage	Phase C Voltage	Vnavg_V
2	2020-07-28T00:00:00-0400	60	121.26265	121.529922	121.542236	121.444931
3	2020-07-28T00:01:00-0400	59.99	121.201187	121.476028	121.484512	121.387245
4	2020-07-28T00:02:00-0400	60	121.322754	121.591568	121.608238	121.507523
5	2020-07-28T00:03:00-0400	59.98	121.591873	121.860107	121.876732	121.77623
6	2020-07-28T00:04:00-0400	59.99	121.462952	121.727982	121.74501	121.645309
7	2020-07-28T00:05:00-0400	60	121.439682	121.704102	121.722427	121.62207
8	2020-07-28T00:06:00-0400	60.01	121.604553	121.870628	121.886559	121.787254
9	2020-07-28T00:07:00-0400	60.01	121.575661	121.840652	121.861496	121.759262
10	2020-07-28T00:08:00-0400	60	121.57576	121.844376	121.85714	121.759079
11	2020-07-28T00:09:00-0400	60.01	121.479614	121.743431	121.760193	121.661087
12	2020-07-28T00:10:00-0400	60	121.616409	121.883629	121.894691	121.798241
13	2020-07-28T00:11:00-0400	60.01	121.593796	121.856827	121.872414	121.774353
14	2020-07-28T00:12:00-0400	60.01	121.69957	121.969322	121.985489	121.884804
15	2020-07-28T00:13:00-0400	60.01	121.625816	121.893471	121.908829	121.809372
16	2020-07-28T00:14:00-0400	59.99	121.652328	121.93058	121.94088	121.841263
17	2020-07-28T00:15:00-0400	59.99	121.7798	122.050537	122.061562	121.963966
18	2020-07-28T00:16:00-0400	59.99	121.836487	122.110878	122.123596	122.023643

## 10.2 Writing To Modbus Device

### Adding the device

After the template with Function 16/15 is created, add a new device with the template. Then specify the connection method (Protocol) to that Modbus device (Modbus RTU/Modbus TCP).

**NOTE:** Refer to chapter 7 on how to add/create Modbus Templates on the AcuLink 810.

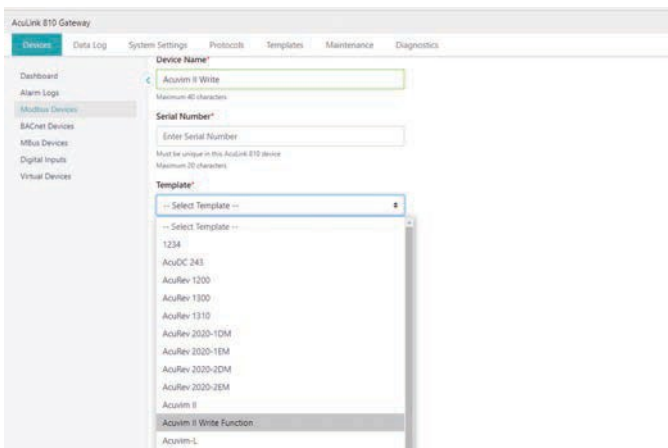

Users will be able to see the device connected under the Modbus device list. In this example, the writing template is connected with **Acuvin II TCP .94**.

Device Name	Interface	Protocol	Serial Number	Status	Alarms	Action
Acuvin I_V1_221	Ethernet	Modbus TCP	221	OK	1	
Acuvin II TCP .94	Ethernet	Modbus TCP	94	OK	1	
Acuvin II_110	RS485	Modbus RTU	AH1405468	OK	0	
Acuvin I_204	RS485	Modbus RTU	AH1605218	OK	0	
MS24-49	Mesh	Modbus RTU	AH1806288	OK	0	
MS24-47	Mesh	Modbus RTU	AH1806333	OK	0	
MS24-48	Mesh	Modbus RTU	AH1806309	OK	0	
MS24-61	Mesh	Modbus RTU	AH1806210	OK	0	
MS24-75	Mesh	Modbus RTU	AH1806218	OK	0	
Acuvin I_V1_207	RS485	Modbus RTU	ALP1810152	OK	0	
AcuDC 243 - 202	RS485	Modbus RTU	DF1601083	OK	0	
Acuvin 1310 - 201	RS485	Modbus RTU	E371609333	OK	0	
USB Device	USB	Modbus RTU	USB	OK	0	
Acuvin II Write	Ethernet	Modbus TCP	Write	OK	0	

Click on the device to view all parameters, the writable parameters will have the write icon located next to the value as per the image below.

Parameter	Value
Relay Output	
Settings	
Frequency	1.000000 [Write]
Protocol 1	0.000000 [Write]
Parity 1	3.000000 [Write]
Password	0.000000 [Write]
Address 1	210.000000 [Write]
Baud Rate 1	19200.000000 [Write]
Voltage Wiring	0.000000 [Write]
Current Wiring	0.000000 [Write]
PT1 (High bit)	0.000000 [Write]
PT1 (Low)	4000.000000 [Write]
PT2	4000.000000 [Write]
CT1	400.000000 [Write]

Click the blue write button besides the value to write register values into the device. For example, the “Voltage Wiring” parameter is “0” by default which is “3LN” (three-phase four-wire) connection. By changing the value to “1” will make the voltage wiring to “3LL” (three-phase three-wire).

AcuLink B1D Gateway

Devices | Data Log | System Settings | Protocols | Templates | Maintenance | Diagnostics

Dashboard | Alarm Logs | Modbus Devices | BACnet Devices | MBus Devices | Digital Inputs | Virtual Devices

Reading Type: Settings [Parameter Define](#)

Display Writable Parameter Only

Parameter	Value
Frequency	1.000000 <a href="#">↗</a>
Protocol 1	0.000000 <a href="#">↗</a>
Parity 1	
Password	
Address 1	
Baud Rate 1	
Voltage Wiring	
Current Wiring	
PT1 (High bit)	0.000000 <a href="#">↗</a>
PT1 (Low)	4000.000000 <a href="#">↗</a>
PT2	4000.000000 <a href="#">↗</a>
CT1	400.000000 <a href="#">↗</a>
CT2	5.000000 <a href="#">↗</a>

**Change Modbus Register Value**

New Value: 1.000000

[Cancel](#) [Submit](#)

Reading parameter set successful

Devices | Data Log | System Settings | Protocols | Templates | Maintenance | Diagnostics

Dashboard | Alarm Logs | Modbus Devices | BACnet Devices | MBus Devices | Digital Inputs | Virtual Devices

Reading Type: Settings [Parameter Define](#)

Display Writable Parameter Only

Parameter	Value
Frequency	1.000000 <a href="#">↗</a>
Protocol 1	0.000000 <a href="#">↗</a>
Parity 1	3.000000 <a href="#">↗</a>
Password	0.000000 <a href="#">↗</a>
Address 1	210.000000 <a href="#">↗</a>
Baud Rate 1	19200.000000 <a href="#">↗</a>
Voltage Wiring	1.000000 <a href="#">↗</a>
Current Wiring	0.000000 <a href="#">↗</a>
PT1 (High bit)	0.000000 <a href="#">↗</a>
PT1 (Low)	4000.000000 <a href="#">↗</a>
PT2	4000.000000 <a href="#">↗</a>
CT1	400.000000 <a href="#">↗</a>
CT2	5.000000 <a href="#">↗</a>
kWh Pulse Constant	5000.000000 <a href="#">↗</a>
kvarh Pulse Constant	5000.000000 <a href="#">↗</a>

# Chapter 11: Digital Inputs

The AcuLink 810 has 8 Digital Input channels. Each Digital Input can be used as an input pulse counter or a digital status monitor.

Each channel has two terminals, a DI terminal and a DI COM terminal. The digital input channels are dry contact inputs, meaning that a voltage supply is required in generating a pulse or digital status.

In the image below you will see a closed circuit on Digital Inputs 1 and 6. The positive output is connected to the DI channel input and negative output is connected to the DI Common input.

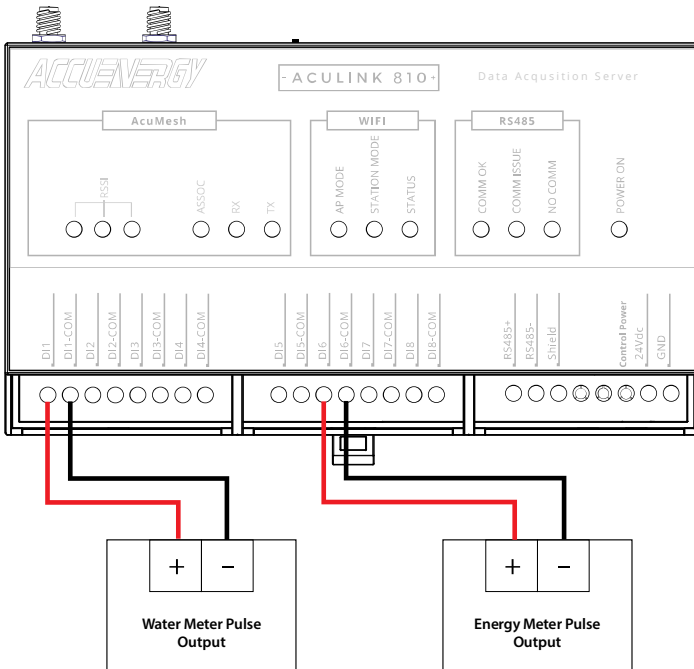

On the AcuLink 810 web interface, the Digital Inputs connected are shown as seen below. The Accumulate column represents if the DI channel is configured for Pulse or Digital Status; if the box is checked the channel is pulse and if unchecked it is status.



Digital Input	Description	Count	Multiplier	Reading	Unit	Accumulate
Digital Input 1	Water Meter	1	0.234	0.234	mL	<input type="checkbox"/>
Digital Input 2	Gas Meter	2	1.267	2.534	m3	<input type="checkbox"/>
Digital Input 3	Channel 3	1754	1.000	1754.000	\$	<input type="checkbox"/>
Digital Input 4	Alarm Status	-	1.000	0.000	-	<input type="checkbox"/>
Digital Input 5	Bowser Status	1	1.000	1.000	-	<input type="checkbox"/>
Digital Input 6	Channel 6	500	10.000	5000.000	-	<input type="checkbox"/>
Digital Input 7	Channel 7	72	0.156	1.072	-	<input type="checkbox"/>
Digital Input 8	Channel 8	8	1.000	8.000	-	<input type="checkbox"/>

Users can switch between pulse counter and digital status by enabling the manual edit button. Once enabled users can check/uncheck the Accumulate box. The digital input channel settings can also be modified, details such as the channel description, count, multiplier, and unit can be configured.

**NOTE:** If the user manually edits DI, all changes must be saved in order for them to take effect.

Digital Input	Description	Count	Multiplier	Reading	Unit	Accumulate
Digital Input 1	Water Meter	1	0.234	0.000	mL	<input type="checkbox"/>
Digital Input 2	Gas Meter	0	1.267	0.000	m3	<input type="checkbox"/>
Digital Input 3	Channel 3	0	1.000	0.000	\$	<input type="checkbox"/>
Digital Input 4	Alarm Status	0	1.000	0.000	-	<input type="checkbox"/>
Digital Input 5	Bowser Status	0	1.000	0.000	-	<input type="checkbox"/>
Digital Input 6	Channel 6	0	1.000	0.000	-	<input type="checkbox"/>
Digital Input 7	Channel 7	0	1.000	0.000	-	<input type="checkbox"/>
Digital Input 8	Channel 8	0	1.000	0.000	-	<input type="checkbox"/>

When the **Manual Edit** slider is enabled, the user has the ability to manually configure each Digital Input's Description, Count, Multiplier, Reading, and Unit, respectively.

If the user manually edits DI, all changes must be saved in order for them to take effect.

## 11.1 Device Alarm

To configure over/under alarms in the AcuLink 810, users must log in with Admin access. Alarms can be added to all devices including Modbus, BACnet and MBus devices. To create a device alarm select the device from the **Devices** page, then select the **Alarm** tab.

Device Name	Interface	Protocol	Serial Number	Status	Alarms	Action
Acuvim L V3 -221	Ethernet	Modbus TCP	221	ON	0	[Action]
Acuvim II TCP -94	Ethernet	Modbus TCP	94	ON	0	[Action]
MESH-69	Mesh	Modbus RTU	AH18063288	ON	0	[Action]
MESH-67	Mesh	Modbus RTU	AH18063303	ON	1	[Action]
MESH-68	Mesh	Modbus RTU	AH18063309	ON	0	[Action]
MESH-65	Mesh	Modbus RTU	AH18063310	ON	0	[Action]

Label	Parameter	Min	Max	Value	Status	Action
No Data						

Click on **Add Alarm**

**Label:** Users can configure the label for the alarm.

**Parameter:** Select the Parameter you wish to monitor for over/under limit.

**Minimum:** Enter the minimum value the parameter should be at in the Min field. Any value lower than the Min value will trigger the alarm.

**Maximum:** Enter the maximum value the parameter should have before it triggers the alarm in the Max field.

Click on **Save** to create the device alarm.

**NOTE:** Alarms are scanned every minute, if there is a change in data a couple seconds apart the AcuLink 810 may not be able to register the alarm.

AcuLink 810 Gateway

Devices | Data Log | System Settings | Protocols | Templates | Maintenance | Diagnostics

Dashboard  
Alarm Logs  
Modbus Devices  
BACnet Devices  
MBus Devices  
Digital Inputs

### Modbus Device - 221

Reading | Alarm | Configuration

#### Add Alarm

**Label**  
  
 Maximum 40 characters

**Parameter\***

**Min Value**  
  
 Range: -2147483648 - 2147483647

**Max Value**  
  
 Range: -2147483648 - 2147483647

Once the alarm has been configured, it will appear under the Parameter list in the Alarms tab. This page will give you a summary of the alarm and will let users know the alarm max/min, the parameter being alarmed and the status of the alarm. Users can delete the alarm and reconfigure the alarm setting under the Action tab.

If the parameter is in alarm mode, the value will be displayed in red and the Alarm status will show a red caution symbol. The AcuLink 810 will also display when devices are in alarm mode from the Dashboard as well as the devices page.

AcuLink 810 Gateway

Devices | Data Log | System Settings | Protocols | Templates | Maintenance | Diagnostics

Dashboard  
Alarm Logs  
Modbus Devices  
BACnet Devices  
MBus Devices  
Digital Inputs

### Modbus Device - AH18063303

Reading | Alarm | Configuration

Label	Parameter	Min	Max	Value	Status	Action
Low Voltage	Phase A Line-to-Neutral Voltage	10	125	0.000000		

- Dashboard
- Alarm Logs
- Modbus Devices
- BACnet Devices
- MBus Devices
- Digital Inputs

### Dashboard

**Offline Devices**

Device Name	Interface	Protocol	Serial Number
Bridge Meter 1	Ethernet	Modbus TCP	Bridge1
Bridge Meter 10	Ethernet	Modbus TCP	Bridge10
Bridge Meter 20	Ethernet	Modbus TCP	Bridge20
MESH TEST1	Mesh	Modbus RTU	MESH2
19487258E61E3C07	Ethernet	MBus	GW19487258E61E3C07
19495028E61E3C07	Ethernet	MBus	GW19495028E61E3C07

**Alarms**

Device Name	Alarms	Interface	Protocol	Serial Number
MESH-67	1	Mesh	Modbus RTU	AH18063303
WE82_163	1	Ethernet	BACnet IP	163

*Up since Wednesday, April 1, 2020 4:48 PM*

AcuLink 810 Gateway

- Devices
- Data Log
- System Settings
- Protocols
- Templates
- Maintenance
- Diagnostics

- Dashboard
- Alarm Logs
- Modbus Devices
- BACnet Devices
- MBus Devices
- Digital Inputs

### Modbus Devices

Add Device
Search Device

Device Name	Interface	Protocol	Serial Number	Status	Alarms	Action
Acuvin L V3_221	Ethernet	Modbus TCP	221	ON	0	[X]
Acuvin II TCP_94	Ethernet	Modbus TCP	94	ON	0	[X]
MESH-69	Mesh	Modbus RTU	AH18063288	ON	0	[X]
MESH-67	Mesh	Modbus RTU	AH18063303	ON	1	[X]
MESH-65	Mesh	Modbus RTU	AH18063310	ON	0	[X]
Bridge Meter 1	Ethernet	Modbus TCP	Bridge1	OFF	0	[X]
Bridge Meter 10	Ethernet	Modbus TCP	Bridge10	OFF	0	[X]
Bridge Meter 20	Ethernet	Modbus TCP	Bridge20	OFF	0	[X]

## 11.2 Alarm Log

When the alarm is triggered, the user will be able to see the triggering detail under the Alarm Logs page.

From here users can search and filter all device alarms by entering in the interval, serial number and monitor ID into the search criteria. Click on reset to clear the filtered search.

AcuLink 810 Gateway

Devices | Data Log | System Settings | Protocols | Templates | Maintenance | Diagnostics

Dashboard

- Alarm Logs
- Modbus Devices
- BACnet Devices
- Mbus Devices
- Digital Inputs

### Alarm Log

Interval:  Serial Number:  Monitor ID:

Timestamp	Monitor ID	Device Name	Serial Number	Monitor Label	Parameter	Status	Min	Max	Value	Reason
2020-04-01 16:49:31	6	WEB2_163	163	Frequency High	Frequency / Hz	▲	40	50	59.990	OVERFLOW
2020-04-01 16:48:01	6	WEB2_163	163	Frequency High	Frequency / Hz	▲	40	50	0.000	UNDERFLOW
2020-04-01 16:27:33	6	WEB2_163	163	Frequency High	Frequency / Hz	▲	40	50	59.960	OVERFLOW
2020-04-01 16:27:03	6	WEB2_163	163	Frequency High	Frequency / Hz	▲	40	50	0.000	UNDERFLOW
2020-04-01 16:11:32	6	WEB2_163	163	Frequency High	Frequency / Hz	▲	40	50	59.980	OVERFLOW
2020-04-01 16:11:03	6	WEB2_163	163	Frequency High	Frequency / Hz	▲	40	50	0.000	UNDERFLOW
2020-04-01 15:30:32	6	WEB2_163	163	Frequency High	Frequency / Hz	▲	40	50	60.000	OVERFLOW
2020-04-01 15:30:03	6	WEB2_163	163	Frequency High	Frequency / Hz	▲	40	50	0.000	UNDERFLOW
2020-03-26 09:00:02	6	WEB2_163	163	Frequency High	Frequency / Hz	▲	40	50	60.000	OVERFLOW
2020-03-26 08:59:32	6	WEB2_163	163	Frequency High	Frequency / Hz	▲	40	50	0.000	UNDERFLOW

Previous 1 2 Next 10/page

## 11.3 Email Alarm Notifications

The AcuLink 810 can send emails based on Reports or if there is an alarm event. To configure the AcuLink 810 to send emails, log in to the AcuLink 810 web interface with Admin access. To configure alarm emails click on the **System Settings** tab and select **Email**.

The user must first configure their Email server and details in order for the gateway to send the emails.

**Email Server:** Enter the SMTP Server for the email account.

**Email Port:** Enter the outgoing port number the SMTP uses to send emails.

**TLS/SSL:** Users can choose to turn on/off the TLS encryption or keep it on auto.

**Sender Name:** Enter the sender name of the email.

**From Email Address:** Users can specify the email address they receive the email from.

**Username:** Enter the email address for the emails authentication.

**Password:** Enter the password for the email address in Username.

Click on **Save** once all settings are configured.

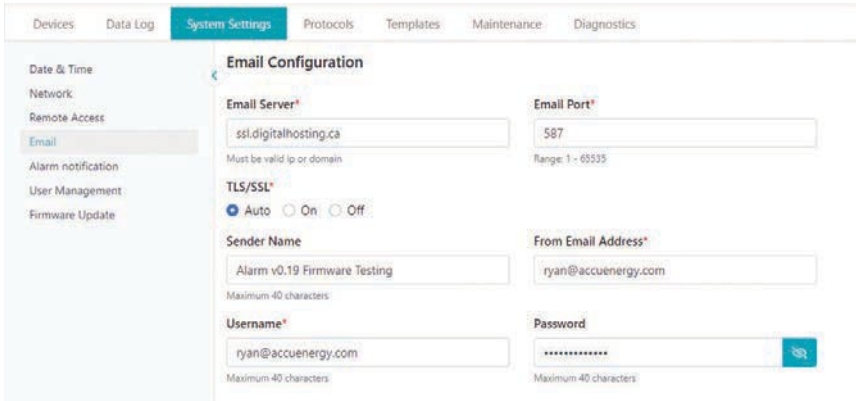

Next users must configure the alarm notification settings receive the email addresses when the alarm is triggered. This can be done on the **Alarm notification** page.

Enable the alarm notification and configure the following:

**Recipients 1-3:** Enter the name of the email address in the Email Recipient field. There can be a maximum of 3 email recipients.

**Email Interval:** Select the email interval, by default it is 5 minutes, the range is from 1-10 minutes.

Click **Save** to confirm the settings. Users can test the emails by clicking on the **Test Emails** button, this will let the user know if the AcuLink can reach the emails listed in the recipients list or not. If successful a test email will be received.

If emails were configured for alarm events, the recipients will also receive an email to be notified.

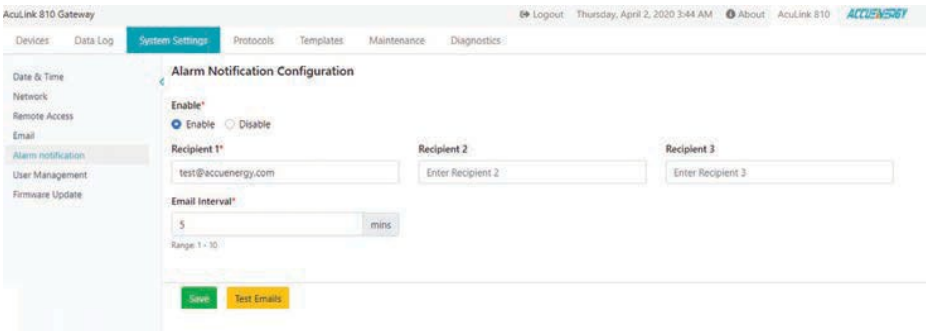

# Chapter 12: Data Logging

## 12.1 Data Loggers

The AcuLink 810 supports data logging to its 8GB of internal memory. When the memory is full the oldest data log entries will be overwritten. To configure the AcuLink 810 to log the device data click on the **Data Log** tab and select **Data Loggers**.

The AcuLink 810 has 3 data loggers, where the user can either save device data to its internal memory as well as post the data to an external HTTP/FTP server. The three loggers allow users to have different types of loggers with different logging intervals, log file formats, etc as desired by the user.

- **Data Log Enable:** Select Enable to **Enable** the data log.
- **Post Channel:** Select the Post Channel from the drop-down list:
  - None: AcuLink 810 will log and store the data on its memory.
  - Post Channel 1/2/3: AcuLink 810 will log and push the data to the configured post channel. Users will not be able to select the post channel if it is disabled.

**NOTE:** For more information on configuring the Upload Protocol refer to section 7.10.2 of this User's Manual for the post channel configuration.

- **Timestamp Format:** Select the format of the timestamp for the data that is logged. The format for the timestamp can be based on the Local Time, UTC Seconds or based on ISO8601 Format.
- **Log File Name Format:** Select the format of the log file name for the data that is logged. The format for the log file name can be based on UTC Timestamp or Time interval Format. An example of each file name format is shown next to each setting.
- **Log File Format:** For users sending data external HTTP or FTP servers they have the option to select the type of file format the log file is sent as. The two formats are CSV and JSON.

**NOTE:** The log data is saved directly to the AcuLink 810 memory, and the CSV file will be created when downloading the log. JSON is only supported when posting the log file to an HTTP or FTP server.

- **Log Interval:** Select how frequently the module will log data to the file from the drop-down list. The logging interval can be from 1 minute to 1 month. For logging intervals faster than 1 minute please see Rapid logger in section 7.10.2 of the user manual.

- **Log File length:** Select the length of the log file, it can be from 1 minute to 1 month. The log file length is in reference to the post channels sending interval, for example if the log interval is 1 minute and the log file length is 5 minutes the log file will be sent to the external server every 5 minutes. If the user is only configuring the logger to save data on the 810's internal memory the log file length setting is irrelevant and can be ignored.

**NOTE:** The log interval must be less than or equal to the log file length.

- **Log File Name Prefix:** Provide a name for the log file which will be appended to the beginning of the log file. By default **logger1** will be appended to the beginning of the log file. If configuring Data **Logger 2** the default name prefix is **logger2**, and if configuring Data Logger 3 the default name prefix is **logger3**.
- Select the device(s) to log the data for. Users have the option to log Modbus, BACnet, and MBus devices.

When all of the settings are entered correctly, click on **Save**.

**NOTE:** For more information on downloading and deleting the data logs, please refer to the 'Data Management' section of this User's Manual.

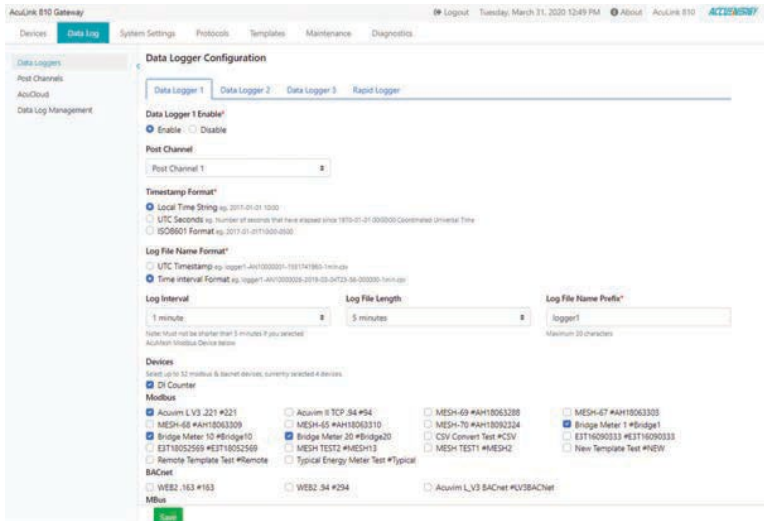



### 12.1.1 Rapid Logger

The AcuLink 810 supports the rapid logging function, where the user has the ability to log data at intervals as fast as 1 second.

- **Rapid Data Logger Enable:** Select **Enable** to begin the rapid logging function.
- **Post Channel:** Select the Post Channel from the drop-down list:
  - None: AcuLink 810 will log and store the data on its memory.
  - Post Channel 1/2/3: AcuLink 810 will log and push the data to the configured post channel. Users will not be able to select the post channel if it is disabled.
- **Timestamp Format:** Select the format of the timestamp for the data that is logged. The format for the timestamp can be based on the Local Time, UTC Seconds or based on ISO8601 Format. An example of each time format is shown next to each setting.
- **Log File Name Format:** Select the format of the log file name for the data that is logged. The format for the log file name can be based on UTC Timestamp or Time interval Format. An example of each file name format is shown next to each setting.
- **Log Interval:** Select how frequently the module will log data to the file from the drop-down list. The logging interval can be from 1 second to 30 seconds.
- **Log File Length:** Select the length of the log file, it can be from 1 minute to 1 month. The log file length is in reference to the post channels sending interval, for example if the log interval is 1 minute and the log file length is 5 minutes the log file will be sent to the external server every 5 minutes. If the user is only configuring the logger to save data on the 810's internal memory the log file length setting is irrelevant and can be ignored.
- **Log File Name Prefix:** Provide a name for the log file which will be appended to the beginning of the log file. By default the prefix for the rapid logger is **loggerRapid**.
- **Devices:** The user can select the device for the rapid logger.

**NOTE:** Only Modbus devices connected via RS485 can be logged using the Rapid Logger.

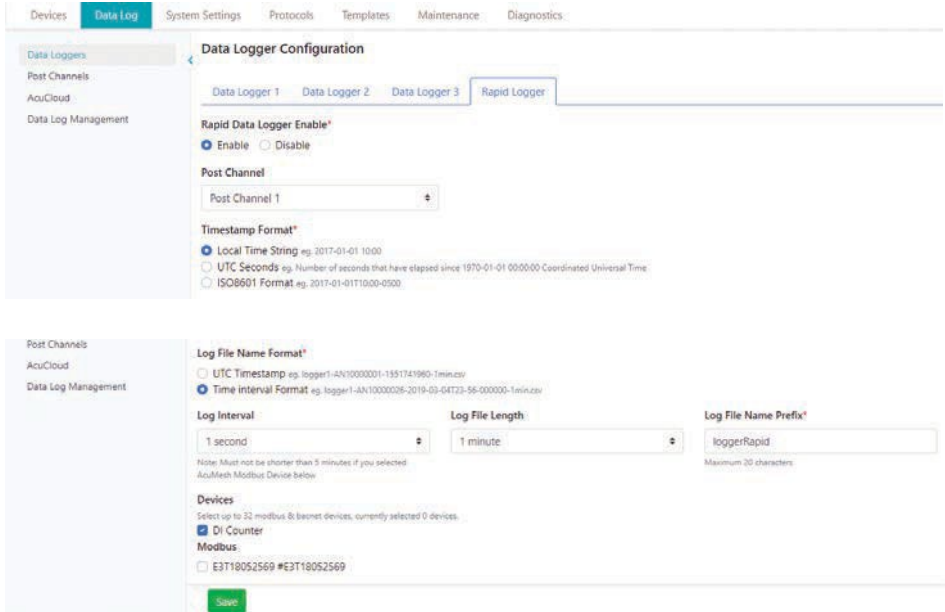

## 12.2 Post Channels

The AcuLink 810 supports 3 Post Channels that will allow users to post device data to external HTTP/FTP/SFTP servers. To configure the HTTP/FTP/SFTP data forward from the web interface click on the **Data Log** tab and select **Post Channels**.

To configure the post channels select the corresponding post channel tab.

### 12.2.1 HTTP Post Method

The HTTP post method allows the user to post meter data to an HTTP/HTTPS server.

**Post Channel Enable:** Select **Enable** to enable the post channel data forward.

**Post Method:** Select HTTP/HTTPS from the drop-down menu.

**Post Name Fixed:** Select Yes or No to enable a fixed post name, if yes selected enter in the post name. There is a maximum of 40 characters allowed for the fixed post name.

**HTTP/HTTPS URL:** Select HTTP or HTTPS prefix from the drop-down menu before entering in.

the URL. Next enter in the URL of the server.

**HTTP/HTTPS Port:** Enter the correct port for the HTTP server.

**HTTP/HTTPS Meter ID:** Enter in the meter ID.

Once the settings are entered correctly click on **Save**. After the settings are saved, users can use the **Test Post Channel** button to test whether the AcuLink 810 can successfully reach the HTTP/HTTPS server.

**NOTE:** If users receive a fail message, please verify the server URL, port number and double-check the network connectivity.

If the AcuLink 810 loses its network connection the gateway can back up 3000 post files on its internal memory. After 3000 post files the data will start to over write from the oldest post file. Users can clear the cached post files by using the **Clear Post Channel Logs** button.

The screenshot displays the 'Post Channel Configuration' page in a web application. The page has a navigation menu on the left with options like 'Data Loggers', 'Post Channels', 'AcuCloud', and 'Data Log Management'. The main content area is titled 'Post Channel Configuration' and shows three tabs: 'Post Channel 1', 'Post Channel 2', and 'Post Channel 3'. Under 'Post Channel 1', there are several configuration options:
 

- Post Channel 1 Enable\***: Radio buttons for 'Enable' (selected) and 'Disable'. A note below states: 'Cannot be disabled. This Post Channel is used by Data Logger 1, Data Logger d.'
- Post Method\***: A dropdown menu set to 'HTTP/HTTPS'.
- Post Name Fixed\***: Radio buttons for 'Yes' and 'No' (selected).
- Post File Name**: A text input field with the placeholder 'Enter Post File Name' and a note 'Maximum 40 characters'.
- HTTP/HTTPS URL\***: A text input field containing 'https:// 18.188.85.147/post' and a note 'Must be valid ip or domain'.
- HTTP/HTTPS Port\***: A text input field containing '800' and a note 'Range: 1 - 65535'.
- HTTP/HTTPS Meter ID\***: A text input field containing 'v0.18' and a note 'Maximum 40 characters'.

 At the bottom of the configuration area, there are two yellow buttons: 'Test Post Channel' and 'Clear Post Channel Logs'. A green 'Save' button is located at the very bottom of the page.

### 12.2.2 FTP Post Method

The FTP post method allows the user to post meter data to an FTP server.

**Post Channel Enable:** Select **Enable** to enable the post channel data forward.

**Post Method:** Select FTP protocol.

**FTP URL:** Enter in the FTP URL.

**FTP Port:** Enter the FTP port number.

**FTP Username:** Enter the username to access the FTP server.

**FTP Password:** Enter the password to access the FTP server.

Once all settings are entered correctly, click on **Save**. Users can use the **Test Post Channel** button to determine whether the 810 can reach the FTP server.

**NOTE:** If users receive a fail message, please verify the server URL, port number, username, password and double-check the network connectivity.

Similar to the HTTP posting method, for FTP if the AcuLink 810 loses its network connection the gateway can back up 3000 post files on its internal memory, after 3000 post files the data will start to over write from the oldest post file. Users can clear the cached post files by using the **Clear Post Channel Logs** button.

The screenshot shows the 'Post Channel Configuration' page in a web browser. The page has a navigation bar with tabs for 'Devices', 'Data Log', 'System Settings', 'Protocols', 'Templates', 'Maintenance', and 'Diagnostics'. The 'Data Log' tab is active. On the left, there is a sidebar menu with 'Data Loggers', 'Post Channels', 'AcuCloud', and 'Data Log Management'. The main content area is titled 'Post Channel Configuration' and has three tabs: 'Post Channel 1', 'Post Channel 2', and 'Post Channel 3'. The 'Post Channel 3' tab is selected. The configuration for 'Post Channel 3' includes: 'Post Channel 3 Enable\*' with 'Enable' selected; 'Post Method\*' set to 'FTP'; 'FTP URL\*' set to 'ftp:// 18.188.85.147'; 'FTP Port\*' set to '1002'; 'FTP Username\*' set to 'admin'; and 'FTP Password\*' masked with dots. There are two buttons at the bottom: 'Test Post Channel' and 'Clear Post Channel Logs'.

### 12.2.3 SFTP Post Method

The SFTP post method allows the user to post meter data to an FTP server.

**Post Channel Enable:** Select **Enable** to enable the post channel data forward.

**Post Method:** Select SFTP protocol.

**SFTP URL:** Enter in the FTP URL.

**SFTP Port:** Enter the FTP port number.

**SFTP Username:** Enter the username to access the FTP server.

**SFTP Password:** Enter the password to access the FTP server.

## 12.3 Downloading Data

Under the **Data Log** tab, the user has the option to download data that has already been logged.

Clicking **Data Log Management (Download Log)**:

- **Device:** The user can select the device to download data from.
- **Interval:** The user can choose the interval from which to download.
- **Download:** The user can download the selected file from the device (CSV format).

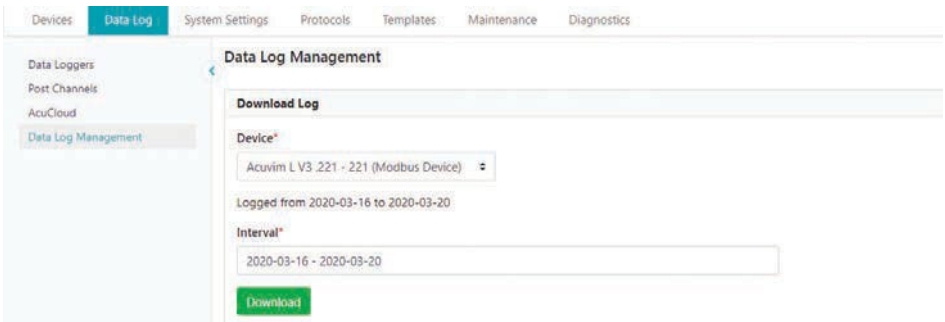

The user also has the ability to delete previously stored logs.

- **Device:** The user can select the device to erase data from.
- **Delete:** This will erase all data from the device selected.

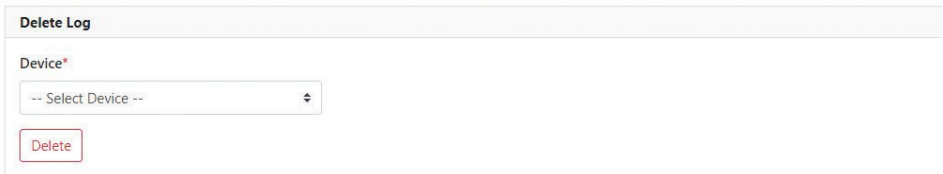

## 12.4 AcuCloud

This chapter will provide instructions on connecting the AcuLink 810 gateway device to the AcuCloud EMS software so that the selected devices connected to the gateway can send their data to the software. This process requires the user to have an existing AcuCloud account, if the user does not have an account they can sign up for AcuCloud directly on our website at: <https://www.accuenergy.com/products/acucloud-energy-management-software-ems/>

This procedure requires users to add the gateway to the software in which a token will be generated through AcuCloud and will act as verification when sending data from the gateway. Finally this generated token will be used to configure the gateway from the AcuLink 810 web interface.

Once the token has been successfully added, the user will be able to monitor, compare and trend the data from devices connected to the gateway.

**NOTE:** Only Modbus devices connected to the AcuLink 810 can be posted to AcuCloud.

Under the **Data Log** tab select **AcuCloud**, the user will first need to select **Enable** under AcuCloud Enable.

- Then copy the Module Serial Number that appears below.

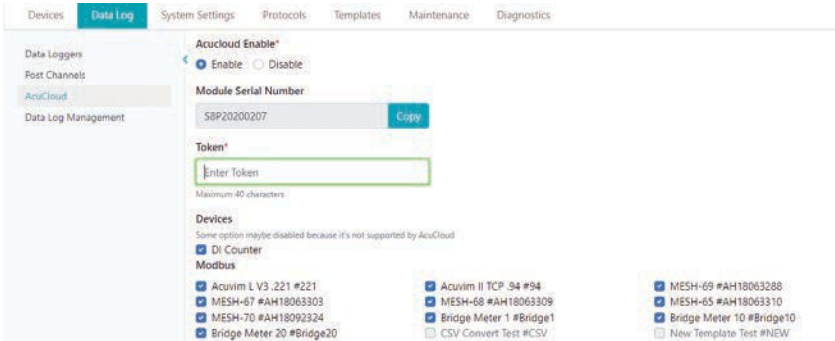

- Next, the user will need to login to AcuCloud with Admin access in order to add devices.

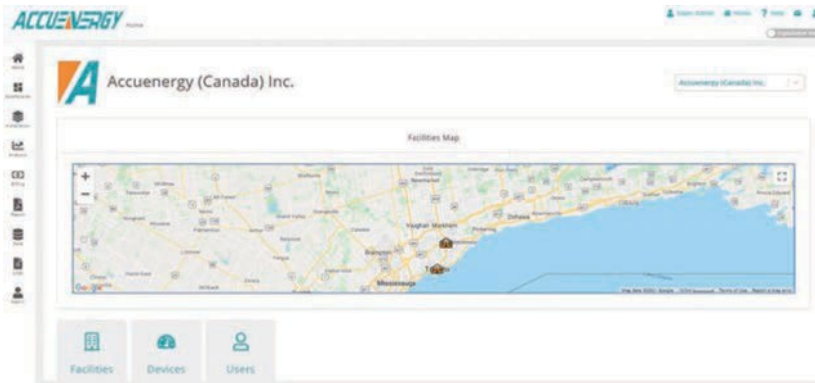

- Adding a new device can be done under the **Facilities** tab by selecting the desired facility and clicking on the **Devices** tab.

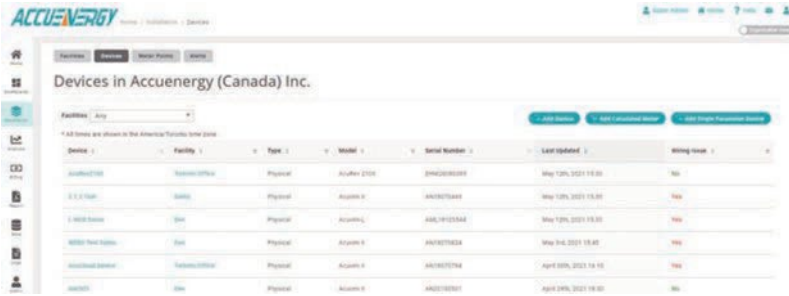

The screenshot shows the 'Devices in Accuenergy (Canada) Inc.' page. It features a table with columns for Device, Facility, Type, Model, Serial Number, Last updated, and Wiring issue. The table lists several devices, including an AcuLink 810 at the Toronto Office and an AcuLink 810 at the E.E. & F. Hall.

Device	Facility	Type	Model	Serial Number	Last updated	Wiring issue
AcuLink 810	Toronto Office	Physical	AcuLink 810	2040200000	May 12th, 2023 10:00	No
E.E. & F. Hall	HALL	Physical	AcuLink 810	AA19070449	May 12th, 2023 10:00	No
2-3000 Station	Site	Physical	AcuLink 810	AA19120344	May 12th, 2023 10:00	No
MSD Test Station	Site	Physical	AcuLink 810	AA19070424	May 14th, 2023 10:00	No
AcuLink 810	Toronto Office	Physical	AcuLink 810	AA19070794	April 05th, 2023 10:00	No
AcuLink 810	Site	Physical	AcuLink 810	AA02100001	April 04th, 2023 10:00	No

Clicking on the **+ New Device** button, the details need to be entered:

- Select the name of the facility in which the device will belong to from the **Facility** drop down list.
- Select the AcuLink 810 from the **Choose a Model** drop down list.
- Select **This is a gateway Device** box.
- Provide a name for the device under **Device Name**.
- Paste the serial number that was copied from the AcuLink 810 web interface under the Serial Number field.
- Provide a description for the location of the device under **Location**.
- Click **SUBMIT**.



The screenshot shows the 'Add Device - Accuenergy (Canada) Inc.' form. It includes fields for Facility (Toronto Office), Model (AcuLink 810), a checked box for 'This is a gateway Device', Device Name (AcuLink 810 Gateway), Serial Number (2040200000), and Location (Electrical Room). There are 'Cancel' and 'Submit' buttons at the bottom.



Once the gateway has been successfully added, a token will be returned on the ensuing page. The user will need to copy the token that is provided as it will be used in the next step to configure the gateway to send its data to AcuCloud.

## Add a New Device

Copy this token to the meter to finish registration.

Device Token

4b7d1865-4ba0-417d-90f9-8190c2a3a69b

COPY TOKEN TO CLIPBOARD

FINISH

Go back to the AcuLink 810 web interface and paste the token that was generated into the AcuCloud **Token** field.

- Click **Save**.
- Then click on **Test AcuCloud** to see if the AcuLink can reach the AcuCloud server.

**NOTE:** If the test connection fails, please check the network settings of the AcuLink 810 and also make sure the AcuCloud URL and token are entered in correctly.

AcuLink 810 Gateway

Devices **Data Log** System Settings Protocols Templates Maintenance Diagnostics

Data Loggers  
Post Channels  
AcuCloud  
Data Log Management

**AcuCloud Configuration** [Link to AcuCloud](#)

Acucloud Enable\*  
 Enable  Disable

Module Serial Number  
 SBP20200207 [Copy](#)

Token\*  
 610eadcb-ea51-4030-b32c-e7aa000d1ccc  
 Maximum 40 characters

Devices  
 Some option maybe disabled because it's not supported by AcuCloud

DI Counter

Modbus

<input checked="" type="checkbox"/> Acuim L V3_Z21 #Z21	<input type="checkbox"/> Acuim II TCP_94 #94	<input checked="" type="checkbox"/> MESH-69 #AH18063288	<input checked="" type="checkbox"/> MESH-67 #AH18063303
<input checked="" type="checkbox"/> MESH-68 #AH18063309	<input checked="" type="checkbox"/> MESH-65 #AH18063310	<input checked="" type="checkbox"/> MESH-70 #AH18092324	<input checked="" type="checkbox"/> Bridge Meter 1 #Bridge1
<input checked="" type="checkbox"/> Bridge Meter 10 #Bridge10	<input checked="" type="checkbox"/> Bridge Meter 20 #Bridge20	<input type="checkbox"/> CSV Convert Test #CSV	<input type="checkbox"/> E3T16090333 #E3T16090333
<input type="checkbox"/> E3T18052569 #E3T18052569	<input type="checkbox"/> MESH TEST2 #MESH413	<input type="checkbox"/> MESH TEST1 #MESH2	<input type="checkbox"/> New Template Test #NEW
<input type="checkbox"/> Remote Template Test #Remote	<input checked="" type="checkbox"/> Typical Energy Meter Test #Typical		

BACnet

<input type="checkbox"/> WEB2_163 #163	<input type="checkbox"/> WEB2_94 #294	<input type="checkbox"/> Acuim_LV3 BACnet #LV3BACNet
--	---------------------------------------	--

Mbus

Master 54 #192.168.1.54

[Test AcuCloud](#) [Clear AcuCloud Post Logs](#)

## AcuLink 810 Data Acquisition Server

The AcuLink 810 gateway is now successfully configured to report to the AcuCloud EMS software. Once a report is created in the AcuLink 810 then the report for the devices it was created for will be posted to AcuCloud.

Check to see if AcuCloud is receiving data from the gateway by going to the **Devices** page in AcuCloud and observing whether the name of the selected devices from the gateway appear in AcuCloud with a Last Received Data timestamp as seen below.

Device ID	Facility	Type	Model	Serial Number	Last Updated	Working Status
833	Toronto Office	Physical	AcuFlex 2020 19 Channel	EM11223344	August 4th, 2020 17:30	No
100	Toronto Office	Physical	AcuFlex 1910	100	October 23rd, 2019 08:40	No
11	Toronto Office	Physical	AcuFlex 1910	11	October 23rd, 2019 09:40	No
21.2 Test	Delta	Physical	AcuFlex 0	8819070489	May 12th, 2021 15:35	Yes
2000	Delta	Physical	AcuFlex 2020 8 Channel	314234234	---	No
2000-MSB-Gateway	Delta	Physical	AcuFlex 2020 19 Channel	EM19129328	December 8th, 2020 12:43	No
AcuCloud Gateway	Toronto Office	Physical	AcuFlex 0	AM19070794	April 30th, 2021 14:18	Yes
AcuLink 810 Delta	Toronto Office	Gateway	ACULINK810	88P20190328	January 23rd, 2022 19:00	No
AcuLink 810 Gateway	Toronto Office	Gateway	ACULINK810	88P18128177	May 12th, 2021 15:45	No
AcuLink 810	Delta	Physical	ACULINK810	88P20029201	---	No

# Chapter 13: Network Diagnostics

The AcuLink 810 network diagnostics page can be used to monitor the status of the gateway device.

In the **Network Status Tab**, under **Diagnostics**, users can see the **Ethernet Network, Routing Table, DNS Server, and Network Status**.

**NOTE:** To see the **WiFi Network Status**, the AcuLink 810 must be configured for Station Mode.

The screenshot shows the 'Network Status' page in the AcuLink 810 web interface. The 'Diagnostics' tab is selected. Under 'Ethernet Network', the following details are displayed:

```

eth0 Link encap:Ethernet HWaddr ec:c3:8a:20:20:82
     inet addr:192.168.1.52 Bcast:0.0.0.0 Mask:255.255.255.0
     UP BROADCAST RUNNING MULTICAST MTU:1500 Metric:1
     RX packets:203116 errors:0 dropped:376 overruns:0 frame:0
     TX packets:82003 errors:0 dropped:0 overruns:0 carrier:0
     collisions:0 txqueuelen:1000
     RX bytes:3034324 (28.9 KiB) TX bytes:4564680 (43.5 KiB)

eth1 Link encap:Ethernet HWaddr ec:c3:8a:20:20:03
     inet addr:192.168.2.213 Bcast:192.168.2.255 Mask:255.255.255.0
     UP BROADCAST RUNNING MULTICAST MTU:1500 Metric:1
     RX packets:28095 errors:0 dropped:0 overruns:0 frame:0
     TX packets:18028 errors:0 dropped:0 overruns:0 carrier:0
     collisions:0 txqueuelen:1000
     RX bytes:18028 (4.0 KiB) TX bytes:769728 (751.6 KiB)

lo Link encap:Local Loopback
     inet addr:127.0.0.1 Mask:255.0.0.0
     UP LOOPBACK RUNNING MTU:65536 Metric:1
     RX packets:4754 errors:0 dropped:0 overruns:0 frame:0
  
```

A yellow 'Refresh Network Status' button is visible at the bottom of the network details section.

The screenshot shows the 'Routing Table' section of the 'Network Status' page. It displays the kernel IP routing table with the following details:

```

TX packets:4754 errors:0 dropped:0 overruns:0 carrier:0
collisions:0 txqueuelen:1
RX bytes:12450935 (11.8 KiB) TX bytes:12450935 (11.8 KiB)

tun0 Link encap:IPSEC HWaddr 00:00:00:00:00:00:00:00:00:00:00:00:00:00:00:00:00:00
     inet addr:10.1.1.5 P-t-P:10.1.1.5 Mask:255.255.0.0
     UP POINTOPOINT RUNNING NOARP MULTICAST MTU:1500 Metric:1
     RX packets:1229 errors:0 dropped:0 overruns:0 frame:0
     TX packets:1277 errors:0 dropped:0 overruns:0 carrier:0
     collisions:0 txqueuelen:500
     RX bytes:100383 (98.0 KiB) TX bytes:12049356 (2.7 MiB)

wlan0 Link encap:Ethernet HWaddr 00:15:ca:39:ac:f5
     inet addr:192.168.100.1 Bcast:0.0.0.0 Mask:255.255.255.0
     UP BROADCAST RUNNING MULTICAST MTU:1500 Metric:1
     RX packets:0 errors:0 dropped:0 overruns:0 frame:0
     TX packets:25 errors:0 dropped:0 overruns:0 carrier:0
     collisions:0 txqueuelen:1000
     RX bytes:0 (0.0 B) TX bytes:3738 (3.6 KiB)
  
```

Below the routing table, a yellow 'Refresh Network Status' button is visible.

Diagnosics

Network Status	0.0.0.0	192.168.1.1	0.0.0.0	UG	100	0	0	eth0
	0.0.0.0	192.168.2.1	0.0.0.0	UG	250	0	0	eth1
	10.1.0.0	0.0.0.0	255.255.0.0	U	0	0	0	tun0
RSTP Status	192.168.1.0	0.0.0.0	255.255.255.0	U	0	0	0	eth0
Host Lookup	192.168.2.0	0.0.0.0	255.255.255.0	U	250	0	0	eth1
	192.168.100.0	0.0.0.0	255.255.255.0	U	0	0	0	wlan0

DNS Server

```
nameserver 8.8.8.8
nameserver 8.8.4.4
```

Network Stat

Active Internet connections (servers and established)

Proto	Recv-Q	Send-Q	Local Address	Foreign Address	State
tcp	0	0	0.0.0.0:199	0.0.0.0*	LISTEN
tcp	0	0	0.0.0.0:80	0.0.0.0*	LISTEN
tcp	0	0	0.0.0.0:34960	0.0.0.0*	LISTEN
tcp	0	0	127.0.0.1:53	0.0.0.0*	LISTEN
tcp	0	0	192.168.100.1:53	0.0.0.0*	LISTEN
tcp	0	0	0.0.0.0:502	0.0.0.0*	LISTEN
tcp	0	0	0.0.0.0:122	0.0.0.0*	LISTEN
tcp	0	0	0.0.0.0:443	0.0.0.0*	LISTEN
tcp	0	0	0.0.0.0:3333	0.0.0.0*	LISTEN

Refresh Network Status

Diagnosics

Network Status	tcp	0	0	192.168.2.213:51346	192.168.2.120:502	ESTABLISHED
	tcp	0	0	127.0.0.1:3333	127.0.0.1:40824	TIME_WAIT
	tcp	0	0	192.168.1.52:57418	10.224.174.54:34000	ESTABLISHED
RSTP Status	tcp	0	378	10.1.1.5:443	10.1.0.1:50766	FIN_WAIT1
	tcp	0	32	10.1.1.5:443	10.1.0.1:50762	CLOSING
Host Lookup	tcp	0	0	127.0.0.1:3333	127.0.0.1:40930	TIME_WAIT
Connection Test	tcp	0	0	10.1.1.5:443	10.1.0.1:50760	TIME_WAIT
NTP Sync Test	tcp	0	0	192.168.1.52:50208	192.168.1.221:502	ESTABLISHED
	tcp	0	0	127.0.0.1:3333	127.0.0.1:40820	TIME_WAIT
	tcp	0	0	192.168.2.213:33062	192.168.2.110:502	ESTABLISHED
	tcp	0	0	192.168.1.52:55804	192.168.1.226:502	ESTABLISHED
	tcp	0	0	127.0.0.1:3333	127.0.0.1:40826	TIME_WAIT
	tcp	0	0	192.168.2.213:30964	192.168.2.101:502	ESTABLISHED
	tcp	0	0	192.168.1.52:44088	192.168.1.94:502	ESTABLISHED
	tcp	0	0	192.168.1.52:55980	5.196.95.208:1883	ESTABLISHED
	udp	0	0	127.0.0.1:53	0.0.0.0*	
	udp	0	0	192.168.100.1:53	0.0.0.0*	
	udp	0	0	0.0.0.0:167	0.0.0.0*	
	udp	0	0	0.0.0.0:168	0.0.0.0*	
	udp	0	0	10.1.1.5:123	0.0.0.0*	
	udp	0	0	192.168.100.1:123	0.0.0.0*	
	udp	0	0	192.168.2.213:123	0.0.0.0*	
	udp	0	0	192.168.1.52:123	0.0.0.0*	
	udp	0	0	127.0.0.1:123	0.0.0.0*	
	udp	0	0	0.0.0.0:123	0.0.0.0*	

Refresh Network Status

In the **RSTP Status** tab, users can check the status of the Rapid Spanning Tree Protocol, if it is being used for the topology of the Ethernet network.

Diagnosics

RSTP Status

Bridge Status

```
cti_client_init: Couldn't connect to server
```

Port Status

```
cti_client_init: Couldn't connect to server
```

Refresh Network Status

In the **Host Lookup** tab, users can use the ping function to see if the AcuLink 810 can communicate over the network it is connected to.

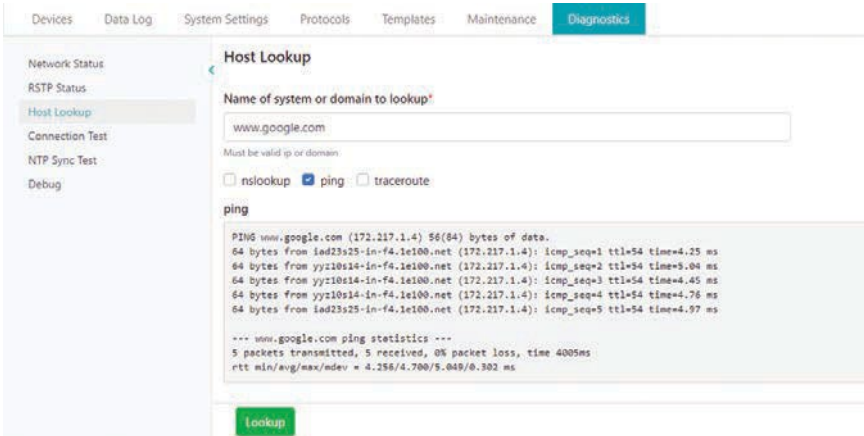

In the **Connection Test** tab, users can test the local network connection of the AcuLink 810. The test will show SUCCESS and PASS as seen below if the network test is successful. Otherwise, the test will show FAIL if network issues are found.

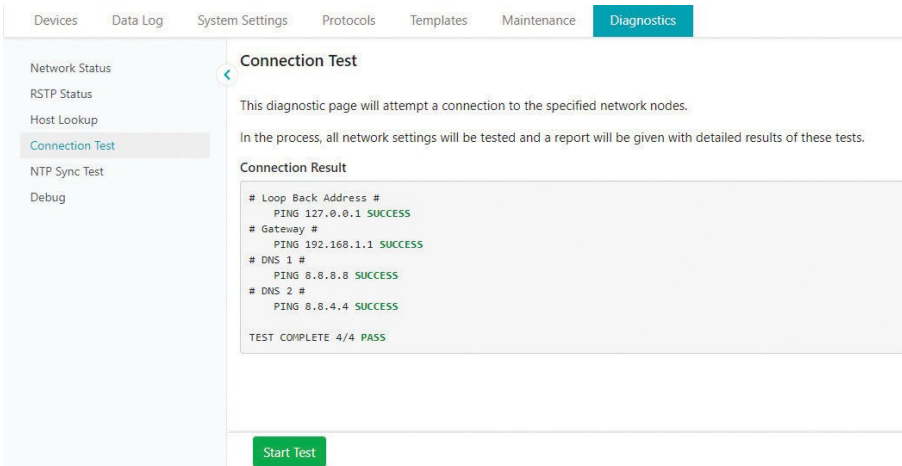

In the **NTP Sync Test** tab, users can determine if the Network Time Protocol is functioning correctly, as seen below.

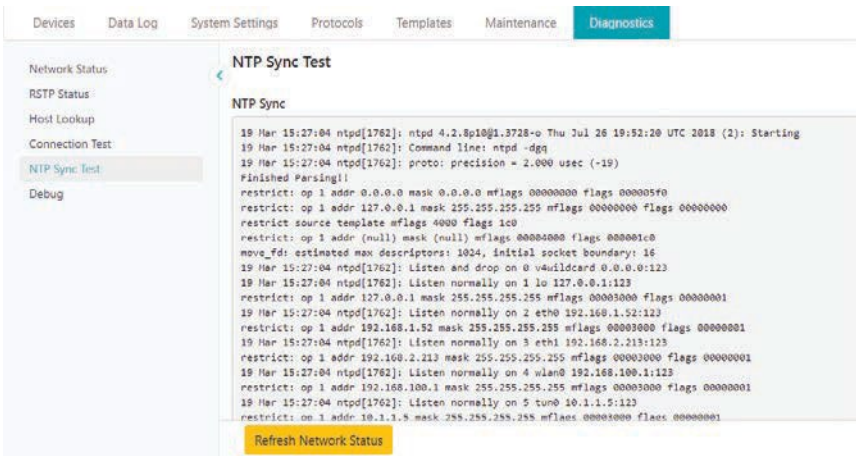

In the **Modbus Debug Log** users can view the Modbus packet requests from the AcuLink 810 to the connected Modbus devices. The Modbus Debug Trace can be enabled, where users can keep track on the Modbus activity for the AcuLink 810. The Modbus debug logs can be exported and downloaded for further analysis.

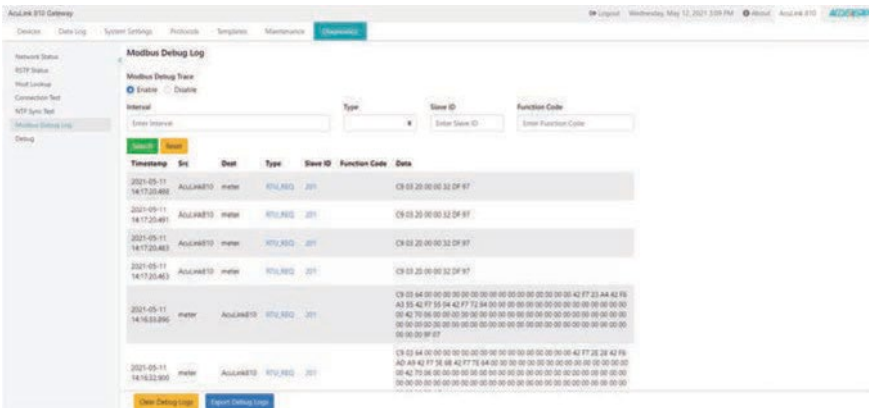

In the **Debug** tab, users can turn ON or turn OFF SSH. From this page, users can also download the AcuLink 810 diagnostic file.

The debug diagnostic options are recommended to be all OFF, as this feature is used for

troubleshooting and can affect the performance of the gateway if turned ON.

By clicking the *Download Diagnostic File* button, users can download a full overview of the AcuLink 810 network. If users are experiencing any issues with the AcuLink 810, the diagnostic file can be sent to Accuenergy technical support for further analysis.

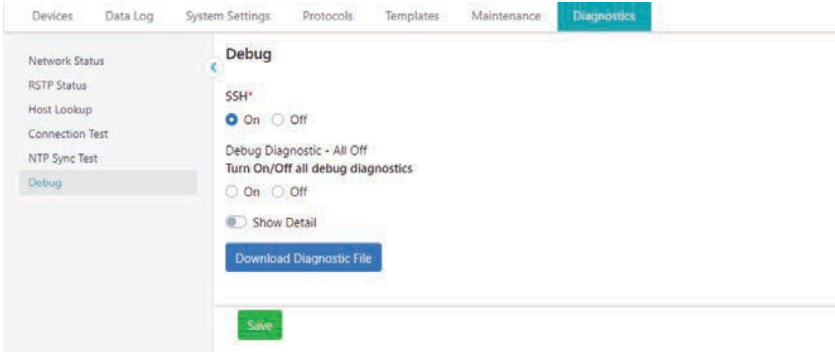

# Chapter 14: Maintenance

## 14.1 System Status

Users can check the AcuLink 810's memory usage under **System Status** located under the **Maintenance** tab.

The system status page provides users with an overview of the AcuLink 810 internal processing, the CPU, RAM, Disk, and RS485 usage can all be monitored.

Users can also manually reboot the device by clicking the **Reboot System** button at the bottom.

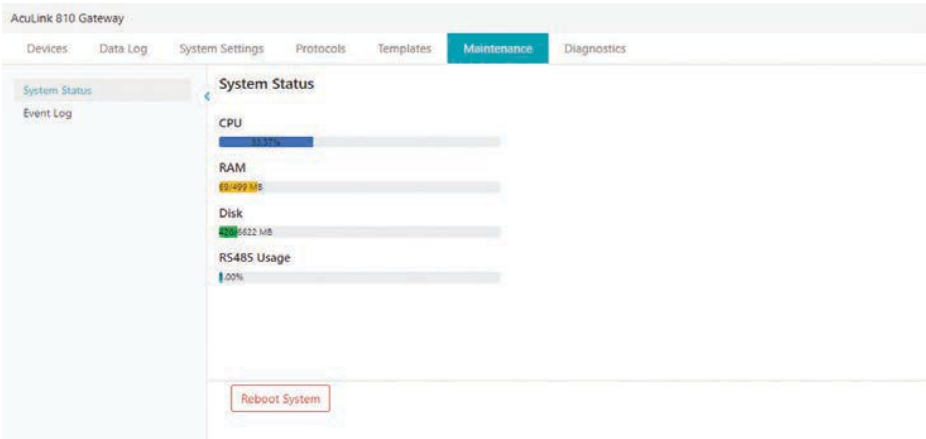



## 14.2 Event Log

Users can check the historical data of the system event by clicking on **Event Log** under the **Maintenance** menu. Event logs can be filtered by selecting the interval and level. The level includes either Error and Info.

Users can also clear and export the event logs by using the buttons at the bottom of the page.

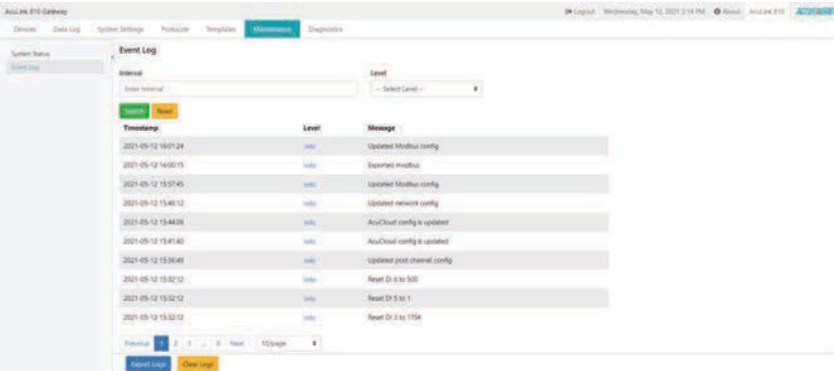

# Chapter 15: Firmware Update

The firmware of the AcuLink 810 can be updated directly from the web interface. To do so click on the **System Settings** tab and select **Firmware Update**.

This page lists the current firmware of the gateway. There are three methods in which users can update the firmware of the 810, either by selecting an option from the auto firmware update options, using the remote firmware function, or by manually updating the firmware.

## 15.1 Auto Firmware Update

The user can choose how to accept firmware updates on the AcuLink 810.

- **Disable:** When selected, this option disables all firmware updates.
- **Critical Update Only:** Automatically updates the firmware when a critical issue is fixed.
- **Automatically Keep Firmware to Latest Version:** The firmware will automatically update on the AcuLink 810 whenever there is an update.

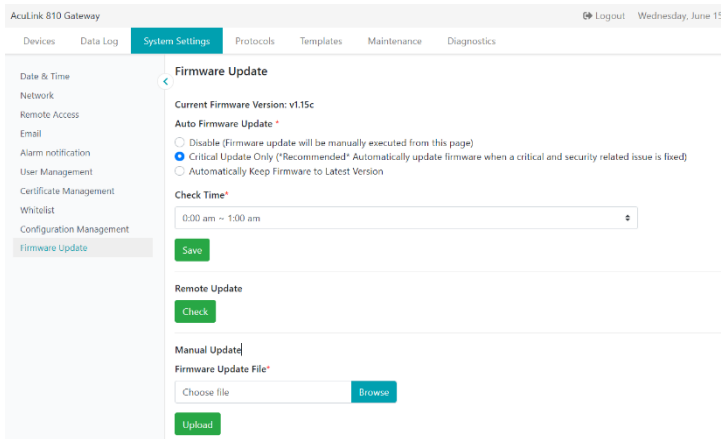

## 15.2 Manual Update

To update the firmware manually, users must have the required firmware file. Start by uploading the firmware file, the file type is .aup.

**NOTE:** For firmware files please contact **Accuenergy Technical Support**.

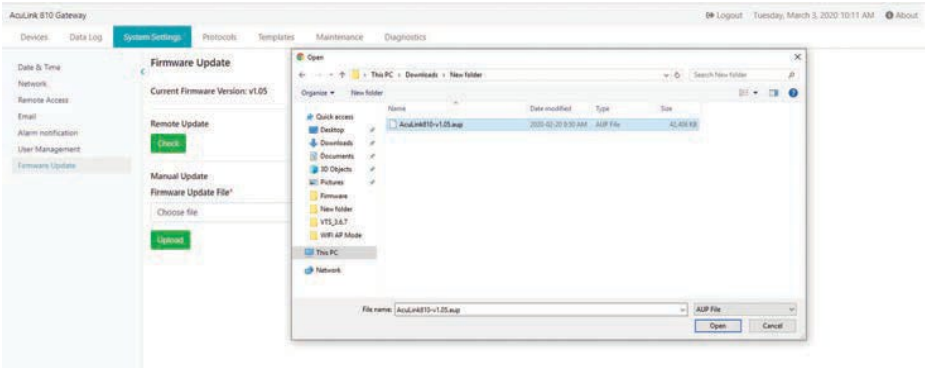



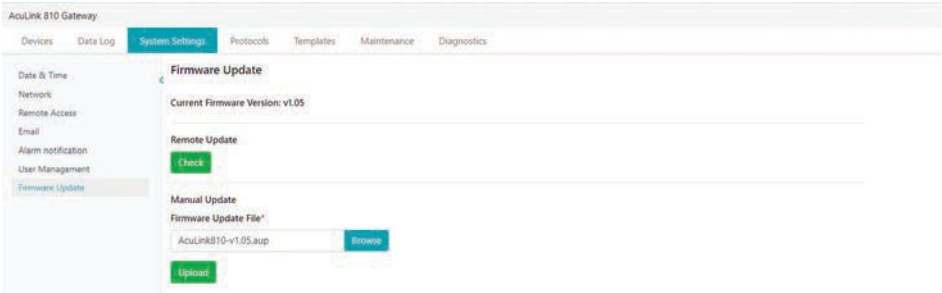

Click on **Upload** once the file is selected.

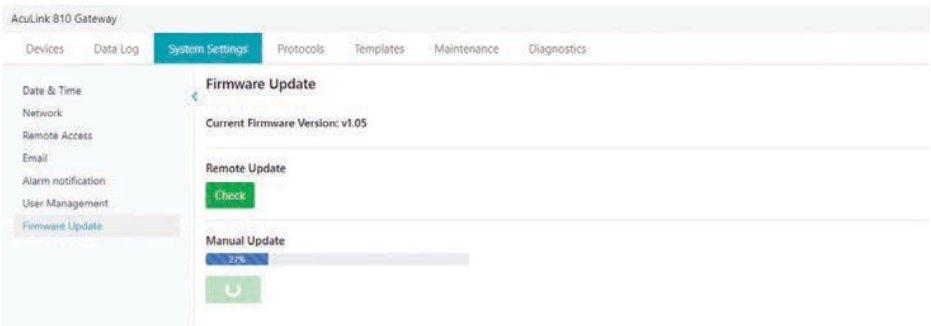

After the firmware has been uploaded successfully, click on **Update**.

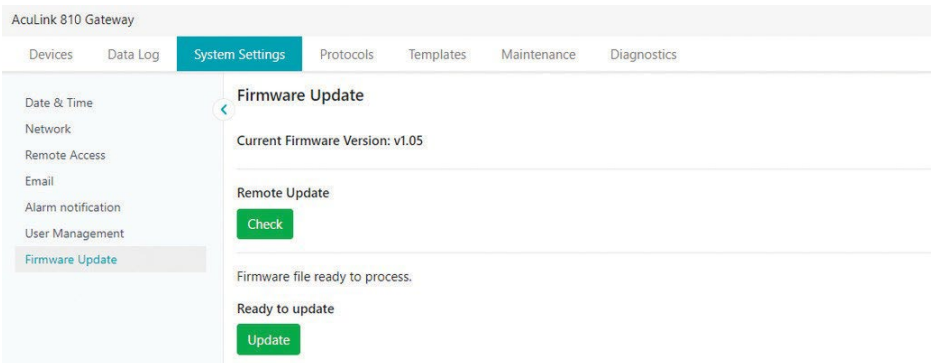

The firmware update will take roughly 2-5 minutes to complete.

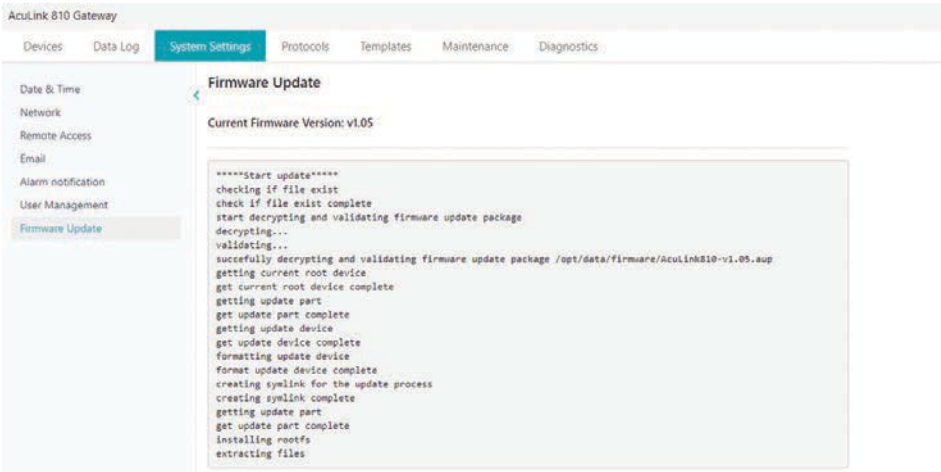

A green banner at the top of the page will be seen notifying the user that the update was successful.

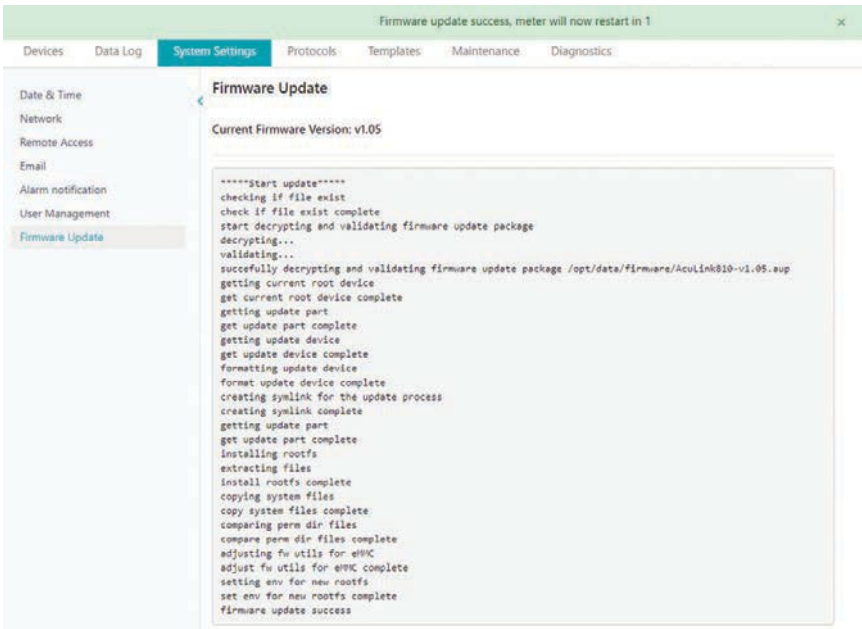

The AcuLink 810 will reboot after the firmware update. The reboot will take approximately 1-2 minutes to complete, the user will be directed to the login screen after the reboot.

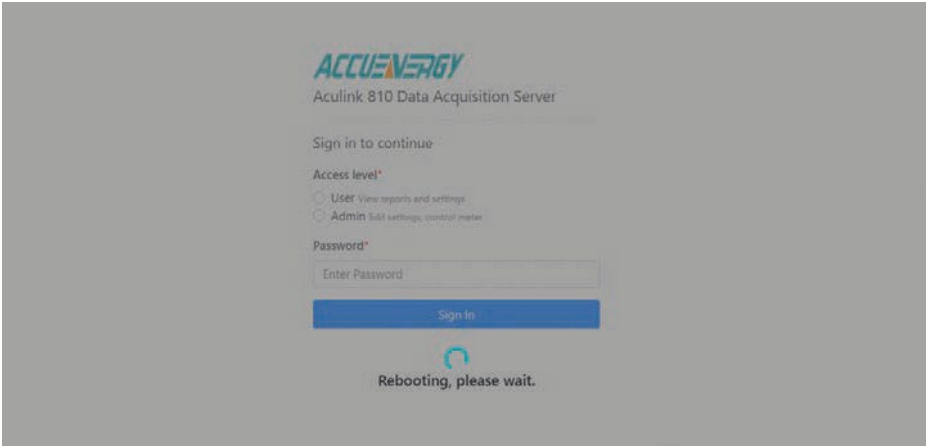

### 15.3 Remote Update

In order to use the remote firmware update there needs to be an internet connection to the AcuLink. Once there is a sufficient connection to the internet users can access Accuenergy's Remote firmware server in order to update the firmware of the AcuLink 810.

Click on the **Check** button.

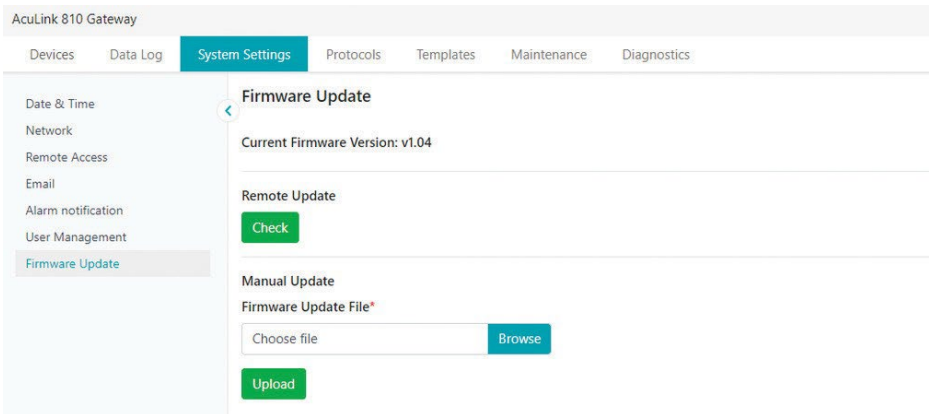

If there is an update found, it will be displayed. It will show the latest version and update detail link for the firmware.

Click on **Update** to begin the updating process.

The screenshot shows the 'AcuLink 810 Gateway' interface. The top navigation bar includes 'Devices', 'Data Log', 'System Settings' (highlighted), 'Protocols', 'Templates', 'Maintenance', and 'Diagnostics'. A left sidebar lists various settings: 'Date & Time', 'Network', 'Remote Access', 'Email', 'Alarm notification', 'User Management', and 'Firmware Update' (highlighted). The main content area is titled 'Firmware Update' and displays the following information: 'Current Firmware Version: v1.04', 'Update Available!', 'Latest Version: v1.05', and 'Update Detail: https://firmware.accuenergy.com'. A green 'Update' button is visible below this information. Under the 'Manual Update' section, there is a 'Firmware Update File\*' label, a text input field containing 'Choose file', a blue 'Browse' button, and a green 'Upload' button.

This screenshot shows the same 'AcuLink 810 Gateway' interface as above, but the 'Firmware Update' process is in progress. The 'Update Available!' section now features a blue progress bar that is 50% full, with a green circular refresh icon below it. The 'Manual Update' section remains visible with the 'Choose file' input, 'Browse' button, and 'Upload' button.



AcuLink 810 Gateway

Devices Data Log **System Settings** Protocols Templates Maintenance Diagnostics

Date & Time  
Network  
Remote Access  
Email  
Alarm notification  
User Management  
Firmware Update

### Firmware Update

Current Firmware Version: v1.04

```

*****start update*****
checking if file exist
check if file exist complete
start decrypting and validating firmware update package
decrypting...
validating...
successfully decrypting and validating firmware update package /opt/data/firmware/aculink810-v1.05.eup
getting current root device
get current root device complete
getting update part
get update part complete
getting update device
get update device complete
formatting update device
format update device complete
creating symlink for the update process
creating symlink complete
getting update part
get update part complete
installing rootfs
extracting files
    
```

After the update is complete the AcuLink 810 will reboot, and users will be required to login to the web interface again.

**ACCUEnergy**  
AcuLink 810 Data Acquisition Server

Sign in to continue

Access level\*

User View reports and settings

Admin Edit settings, control meter

Password\*

Enter Password:

Sign In

Rebooting, please wait.

## Chapter 16: Reset Button

On the AcuLink 810 unit, there is a reset button located on the back of the unit where the Ethernet and USB ports are. This button resets the AcuLink 810 back to default meaning that all devices, data logs, alarm/event log, and device templates will be deleted. The only Device Template that will remain after the reset is the Modbus Gateway Function, however all other Modbus templates will be removed.

After the reset all network communications will be restored back to default meaning the AcuLink will have the following network settings after the reset:

- WiFi Mode - Access Point (AP) mode.
- Ethernet 1 - 192.168.8.101
- Ethernet 2 - DHCP enabled.

To successfully perform a reset on the AcuLink 810 gateway press and hold the reset button for 10 seconds until all LED lights on the unit are flashing. The reset will be complete when the LED lights stop flashing.

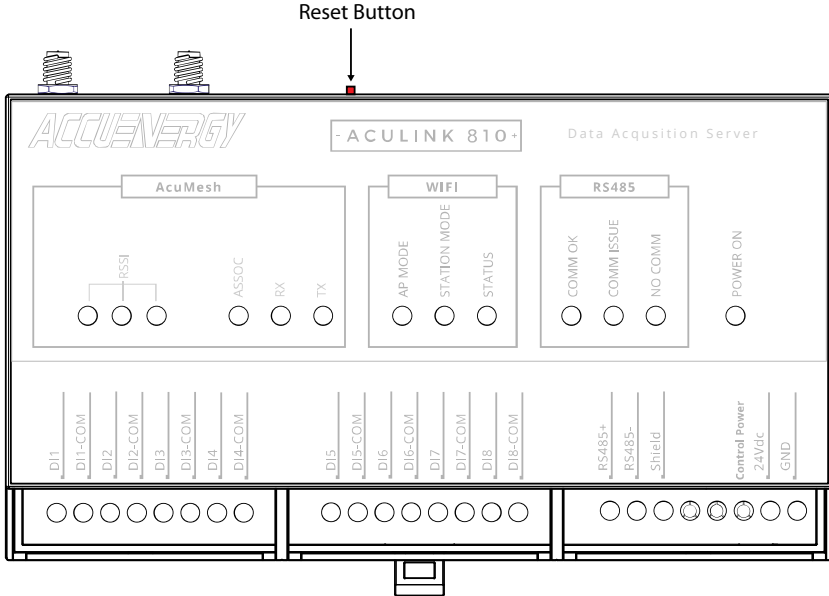



MAKE ENERGY USAGE SMARTER

**ACCUENERGY (CANADA) INC.**

22 Howden, Road  
Toronto, ON M1R 3E4, Canada

TF: 1-877-721-8908  
INT: +1-416-497-4100  
FAX: +1-416-497-4130  
E: [marketing@accuenergy.com](mailto:marketing@accuenergy.com)

**ACCUENERGY SOUTH AFRICA (PTY) LTD**

Castle Walk Corporate Park,  
Block B, Cnr. Nossob & Swakop Street  
Erasmuskloof, Pretoria, 0181  
South Africa

TF: +27 (0) 87 802 6136



Revision Date: May, 2022